

# REQUEST FOR PROPOSALS

For

CONSTRUCTION MANAGEMENT

For

State of Good Repair Bus Stop Improvements Construction



**MARIN COUNTY TRANSIT DISTRICT**  
**711 Grand Ave, Ste. 110**  
**San Rafael, CA 94901**

**Issued December 28, 2018**

**Responses due:**

**4:00 pm, January 16, 2018**

## Timeline

Issue RFP for Construction Management (CM)	December 28, 2018
Deadline to Submit Questions	January 9, 2018
Submission Deadline for CM Proposal	January 16, 2018
Award CM Contract	January 29, 2018
Complete Design & Preparation of Bids by CM	February 14, 2018
Advertise and Begin Bidding Process	February 21, 2018
Award Construction Contract	April 2, 2018
Begin Construction	TBD
Complete Construction	TBD

## Table of Contents

<b>I. Introduction .....</b>	<b>3</b>
<b>II. Project Description .....</b>	<b>3</b>
<b>III. Scope of Services.....</b>	<b>4</b>
<b>IV. General Terms and Conditions .....</b>	<b>7</b>
<b>V. Proposal Format.....</b>	<b>9</b>
<b>VI. Method/Criteria for Selection.....</b>	<b>10</b>
<b>VII. Timeline .....</b>	<b>11</b>
<b>VIII. Appendix A: Sample Short Form Contract .....</b>	<b>12</b>
<b>IX. Appendix B: FTA Grant Contract Provisions (Services).....</b>	<b>22</b>
<b>X. Appendix C: FTA Certification Forms .....</b>	<b>31</b>
<b>XI. Appendix D: California Levine Act Statement .....</b>	<b>36</b>
<b>XII. Appendix E: Project Location and Exhibit of Improvements.....</b>	<b>39</b>

## I. Introduction

Marin County Transit District (Marin Transit) invites qualified consulting firms to submit a proposal to provide Construction Manager (CM) services for the State of Good Repair Bus Stop Improvements project. The project includes improvements to eleven (11) stops located throughout Marin County. **Appendix E** shows the Project Locations and exhibit of improvements.

The selected CM will need experience in providing complete construction management services including: construction management, budget controls, scheduling, administration, construction engineering and inspection, quality assurance, project records and close-out documents. Experience with funds management related to oversight of the project’s financing and cash flow control as well as prior experience with Federal Transit Administration (FTA) funded projects is required.

## II. Project Description

The bus stop improvement project is funded with Federal Transit Administration (FTA) Section 5309 Bus Revitalization funding with a local match using State Public Transportation modernization, Improvements and Service Enhancement Account (PTMISEA) funds. The project is Categorical Exempt under the National Environmental Policy Act (NEPA) as a Class II C08 (Install shelters fencing and amenities) and C15 (Alterations for elderly and disabled).

Construction of the proposed improvements has been estimated to cost approximately \$465,000. Primary construction components will improve bus patron access and comfort throughout Marin County by upgrading up to eleven transit stop locations. The Project will require construction of sidewalks, curb and gutter, and installation of bus stop amenities in the following locations:

### Bid Package

Stop ID	Stop Location	Jurisdiction	Improvements	Estimated Cost
40280	Tamalpais Dr & Madera Blvd	Corte Madera	3a, 3b, 3c, 4a	\$18,700
40392	Lincoln Ave & Grand Ave	San Rafael	3a, 3b, 4a	\$17,700
40490	Red Hill Ave & Sequoia Dr	San Anselmo	1, 2, 3a, 3b, 4a, 5	\$71,100
40449	Medway Rd & E Francisco Blvd	San Rafael	3a, 3b, 4a	\$17,700
40223	Tiburon Blvd & Greenwood Cove Rd	Caltrans	1, 2, 3a, 3b, 4a, 5	\$134,500
41159	Mission Ave & Mary St	San Rafael	1, 2, 5	\$32,600
40572	Los Ranchitos Rd & Golden Hinde Blvd	San Rafael	1, 2, 5	\$29,800
40549	Manuel T Freitas Pkwy & Del Ganado Rd	San Rafael	1	\$25,700
40452	Canal St at Medway Rd	San Rafael	1, 3a, 3b, 3c	\$30,600
40302	Magnolia Ave & Bon Air Rd	Larkspur	1, 2, 3a, 3b, 3c, 4c	\$47,404
40467	Bellam Blvd & E Francisco Blvd	San Rafael	1, 3a, 3b, 3c, 4a, 4c	\$38,605

1. Installation of sidewalk (Type “A” or “B”, depending on location)
2. Installation of curb and gutter
3. Installation of amenities
  - a. Bench
  - b. Shelter
  - c. Trash

- d. Bicycle rack
4. Removal of existing amenities
  - a. Bench
  - b. Shelter
  - c. Trash
5. Saw-cut existing and installation of HMA pavement

### **III. Scope of Services**

The CM, will provide a cohesive planning and delivery effort and act on behalf of Marin Transit. The selected team of experts is expected to provide traditional construction management services encompassing adherence to the approved plans and specifications. Additionally, CM will provide related support services including constructability review and project budgeting. Constructability review must be performed on the progress of design and plans before they are finalized in order to provide suggestions to aid the construction bidding and award process. It is expected that the selected Construction Management firm will provide additional personnel (Resident Engineers, Task Leaders, etc) as needed in addition to the Construction Manager during the project's duration.

The CM shall provide technical and administrative services and coordination oversight for all activities taken on by outside entities in connection with the project. The CM shall maintain a close liaison with Marin Transit's Project Manager.

Construction is not anticipated to last more than two months. Throughout the duration of the project, the CM shall perform the following services that include, but are not limited to, the following:

#### A. Pre-construction Phase

- Conduct a peer review of construction documents (Bid Package, Bid Schedule and Quantity Sheets) and provide comments on constructability including but not limited to methods, materials, and structural components
  - Conduct construction bid process (including setting up and chairing pre-bid meeting, coordinate and respond to bidder questions)
  - Complete review of bids and recommendation for low bidder
  - Review and coordinate analysis of Contractor's submittals with the design team
  - Review and comment on the Contractor's schedule

#### B. Construction Phase

Engineer of Record will be under contract during the project. All coordination will go through Marin Transit unless otherwise authorized.

Provide all necessary project administration including:

- Schedule and conduct all job site and construction meetings, prepare minutes, and distribute to designated parties.
- Develop and maintain construction schedules
- Perform weekly site inspections
- Consistent with construction schedule, provide inspectors for day-to-day on-the-job observation/inspection of work. The inspectors shall make reasonable efforts to guard

- against defects and deficiencies in the work of the Contractor and to ensure that provisions of the contract documents are being fulfilled:
- Prepare daily inspection reports documenting observed construction activities
  - Take and maintain digital photographs providing documentation of construction activities; bind and label them
  - Review the Contractor record drawing markups prior to the "As Builts" being approved
  - Assist in monthly progress payment recommendations
  - Monitor project budget, purchases and payment
  - Verify that construction complies with encroachment permit requirements and conditions. Establish and process job control documents including:
    - daily inspection diaries
    - weekly progress reports
    - monthly construction payments
    - requests for information
    - material certifications
    - material submittals
    - weekly statements of working days, including a detailed record of track time
    - construction change orders
    - review of certified payroll records
    - state documentation
  - Review schedule updates:
    - Compare work progress with planned schedule and notify the Construction Contractor of project slippage; review Contractor's plan to get back on schedule
    - Analyze the schedule to determine the impact of weather and change orders
    - Obtain monthly updates from the Construction Contractor of construction schedule incorporating actual progress, weather delays and change order impacts
    - Negotiate time extensions due to change orders or other delays
  - Assist Marin Transit in negotiation and execution of change orders:
    - Perform quantity and cost analysis as required for negotiation of change orders.
    - Analyze additional compensation claims that are submitted during the construction period and prepare responses
    - Perform claims administration including coordinating and monitoring claims responses, logging claims and tracking claim status
    - Provide a signed letter verifying costs and work for all submitted change orders
  - Review, comment and facilitate responses to requests for information (RFI):
    - Prepare responses to RFI related construction issues
    - Transmit design-related RFIs to design engineer and copy the Marin Transit Project Manager
    - Conduct meetings with the Construction Contractor and other parties as needed to discuss and resolve RFIs
  - Evaluate cost reduction incentive proposals and provide recommendations to the Marin Transit Project Manager for acceptance or denial
  - Monitor and enforce Construction Contractor's compliance with Marin County Storm Water Pollution Prevention Program (SWPPP)
  - Maintain an awareness of safety and health requirements and enforce applicable regulations and contract provisions for the protection of the public and project personnel

- Facilitate any necessary utility coordination with Marin Transit, local jurisdictions, the applicable utility and the Construction Contractor
- Ensure Contractor has proper traffic controls in place during construction for vehicles, buses, bicycles and pedestrians
- Identify actual and potential problems associated with the construction project and consult with the Marin Transit Project Manager and the design engineer
- Prepare a monthly progress report for the Marin Transit Project Manager including a) Cost vs. Budget. b) Construction progress vs. schedule. c) Change order summary. d) Quality of workmanship review; describe all key issues
- Prepare monthly progress payment requests; negotiate differences over amount with the Construction Contractor and process payments through the Marin Transit Project Manager

### C. Quality Assurance

The Construction Manager shall enforce the quality assurance plan, in conformance with the plans and specifications.

- Schedule and perform quality assurance materials testing to verify compliance of the work with the contract documents:
  - Source Inspections
  - Materials Acceptance
- Review test reports submitted by others to substantiate contract compliance
- Ensure that Certificates of Compliance or source release tags are furnished by the Construction Contractor along with the applicable delivered materials at the project site
- Prepare punch lists in advance of completion and establishing management systems for correction of any deficient work

### D. Contract Management Requirements

- Maintain construction documents per federal and/or state requirements
- Enforcement of Labor Compliance requirements, including completion of federal Labor Compliance Pre-job checklist
- Enforcement of Quality Assurance requirements

### E. Post-Construction Phase

- Perform project closeout procedures
  - Coordinate final project inspection
  - Complete funding agency closeout documentation
  - Submit reimbursable documentation
  - Follow-up on Marin Transit receipt of all reimbursements
  - Final funds balance report
- Prepare summary of initial punch list and consolidate comments into final punch list. Finalize the bid items, claims, change orders, punch list items and correct shop drawings
- Oversee completion of record drawing
- Preparation of federal final report including all necessary attachments
- Preparation of Report of Expenditures Checklist includes all necessary attachments
- Transmit all project files and record drawings (on CD) to Marin Transit for archiving

### F. Project Office

CM shall maintain a suitable project office for the duration of the project and CM staff must be available and accessible throughout the construction phase. CM shall provide all necessary safety equipment required for their personnel to perform the work efficiently and safely. Construction Manager Personnel shall be provided with radio or cellular equipped vehicles, digital camera, and personal protective equipment suitable for the location and nature of work involved, and in accordance with local and state requirements.

#### **IV. General Terms and Conditions**

It is imperative that the key personnel providing the construction management services have the background, experience, and qualifications to complete the project. Key project team members should have public agency experience in various capacities, and should be accustomed to working with governmental agencies, and have a good understanding of public agency issues, procedures, and policies. Marin Transit is looking for a qualified team that can provide turn-key services, and be the single point of responsible party representing the agency in the project construction process.

Marin Transit reserves the right to approve all key personnel, individually, for work on this contract. All key staff shall be named in the contract. After the contract is signed, the proposer may not replace key staff unless their employment is terminated or agreed upon by Marin Transit. Marin Transit must approve replacement staff before substitute person is assigned to the Project. Marin Transit reserves the right to request that the proposer replace a staff person assigned to the contract, should Marin Transit consider such a replacement to be for the good of the project.

For inquiries regarding this RFP, contact:

Anna Penoyar, Capital Analyst  
Marin Transit  
415-226-0867  
[apenoyar@marintransit.org](mailto:apenoyar@marintransit.org)

Interested consultants are encouraged to submit written questions to [apenoyar@marintransit.org](mailto:apenoyar@marintransit.org) by 4:00 pm on January 9, 2018. Answers will be posted at [www.marintransit.org](http://www.marintransit.org)

Please provide 5 copies of proposals to Marin Transit, no later than 4:00 PM on Tuesday, January 16, 2018. The entire proposal (excluding cover letter and sections 7 and 8) shall not exceed 20 pages and shall be printed double-sided. Late submittals will not be accepted and will be returned unopened to sender. Fee proposal shall be submitted in separate sealed envelope marked "CONFIDENTIAL - Construction Management for Marin Transit Bus Stop Improvements" along with proposer's name and address. Proposals should be addressed to:

Marin County Transit District  
Attn: Anna Penoyar  
711 Grand Ave, Suite 110  
San Rafael, CA 94901

The cost of preparing, submitting, and presenting a Proposal is at the sole cost and expense of the Consultant. Marin Transit shall not be liable for any pre-contractual expenses incurred by the firm/team in preparation of their proposal.



## V. Proposal Format

Applicants must demonstrate familiarity with public projects, bus stop improvements, and FTA funding requirements and provide description of at least three reference projects completed within the last three years for services requiring similar responsibilities. The proposal (#2-#9 outlined below) should not exceed 20 written pages (single sided, 8-1/2" X 11" pages, minimum font size of 10 pt). Supplemental information such as firm brochures, similar project deliverables, and full resumes can be included in addition to the 20-page limit.

1. **Cover Letter:** Identify the prime consultant and describe any subcontract arrangements. The cover letter shall be signed by the person authorized to negotiate a contract for proposed services with Marin Transit on behalf of the submitting firm/team. Proposers must acknowledge receipt of all issued addenda in the cover letter of the request for qualifications.
2. **Project Understanding and Approach:** Describe your understanding of the project and describe your approach to meeting the task objectives outlined in this request for proposals. Include additional information that may be deemed appropriate to complete the CM services. In addition to items you identify, please discuss:
  - a. The experience your firm/team has in prioritizing projects in multiple locations.
  - b. The experience your firm/team has with transit stop improvements.
  - c. The experience your firm/team has in working with current ADA guidelines and accessible designs.
  - d. Any anticipated issues this project should consider prior to and/or during the course of construction and recommended measures and strategies to avoid these issues.
3. **Construction Management Team:** Describe your team organization, including the qualifications of the prime consultant and any subconsultants included in the team. Please provide evidence of your team's experience in each of the areas identified in this proposal, with emphasis on those relating to similar projects.
4. **Key Staff:** Identify key team members and a brief description of their relevant experience. This section should present staff that will **actively** participate in this effort and become part of the core project team. Include a statement that these key team members will not be removed or reassigned without prior approval of Marin Transit.
5. **Work Plan and Schedule:** Provide a proposed work plan. Provide a detailed description of assumed services anticipated to be performed for this project. Description shall include:
  - a. Identification of major tasks or range of tasks anticipated to complete construction;
  - b. A schedule of expected start dates, milestones, and completion dates for each task; and
  - c. Estimated hours to complete each task and level of effort from identified key staff.

6. **References:** Provide at least three (3) relevant references for the Project Manager (name, affiliation, and current phone number). References must be from recent work (previous three years) similar to the role of the Project Manager that will be required to conduct this work.
7. **Professional Services Contract:** Within the cover letter, indicate your willingness to accept the terms and conditions in the Standard Short Form Contract (**Appendix A**) or list those to which you take exception, and, as appropriate, provide proposed alternate wording. It is not Marin Transit's intent to make substantial changes to the Standard Short Form Contract. Proposer must also acknowledge their willingness to accept the FTA Grant Contract Provisions (**Appendix B**).
8. **Required Forms:** Complete and include all of the forms included in **Appendix C** (FTA Certification Forms) and **Appendix D** (California Levine Act).
9. **Project Cost:** provide a project cost in a sealed envelope, showing the cost for each task, as outlined in this RFP. Include level of effort for each staff person and billing rates for each person. Identify overhead rates and all other applicable charges to program. Fixed costs should be separately identified and tallied. The maximum available budget for Construction Management and support services for Bid Package 1 is \$69,661. The estimated cost for construction is \$464,409.

## VI. Method/Criteria for Selection

Consulting firms interested in being considered for selection to perform services under this RFP must submit a proposal in compliance with this notice. Based on the evaluation of submitted proposals, a list of the top qualified Consultants will be established. Consultants may be requested to participate in an oral presentation. Upon completion of the proposal evaluations and interviews, the Consultants will be ranked and the top-ranked firm will be identified.

Marin Transit reserves the right to select the top-ranked consultant solely based on the written proposal. If for any reason an acceptable contract cannot be negotiated with the top ranked Consultant, negotiations will commence with the next ranked Consultant.

The following criteria will be considered in selection of the successful proposal (relative weights as shown).

Firm Qualifications, with focus on experience gained in successful completion of similar Projects as outlined in this RFP	35
Qualifications of Key Personnel, specialized experience and technical competence in the type of work required and experience with state and local agencies. Additional consideration for experience with Funds Management	30
Adequacy of Resources to perform the work	20
Past performance on contracts in terms of cost control, quality of work, and compliance with performance schedules.	15
	<b>100</b>

**At its sole discretion, Marin Transit reserves the right to amend this RFP, to withdraw all or a portion of this RFP, to award a contract for only a portion of the scope of work described herein, or to decline to award a contract.**

**The current design plans and specifications may be viewed at Marin Transit's office at 711 Grand Ave, Suite 110, San Rafael, California, between the hours of 9 am to 4 pm, and a link to download the files can also be found on Marin Transit's website at [www.marintransit.com/purchasing.html](http://www.marintransit.com/purchasing.html)**

## **VII. Timeline**

The following anticipated timeline to engage the CM Services and thereafter to complete the construction:

### Timeline

---

Issue RFP for Construction Management (CM)	December 28, 2018
Deadline to Submit Questions	January 9, 2018
Submission Deadline for CM Proposal	January 16, 2018
Award CM Contract	January 29, 2018
Complete Design & Preparation of Bids by CM	February 14, 2018
Advertise and Begin Bidding Process	February 21, 2014
Award Construction Contract	April 2, 2018
Begin Construction	TBD
Complete Construction	TBD

## VIII. Appendix A: Sample Short Form Contract

**MARIN COUNTY TRANSIT DISTRICT  
STANDARD SHORT FORM CONTRACT**

**THIS AGREEMENT** is made and entered into this \_\_\_\_ of \_\_\_\_\_, 2011 by and between the MARIN COUNTY TRANSIT DISTRICT, hereinafter referred to as "District" and \_\_\_\_\_  
\_\_\_\_\_, hereinafter referred to as "Contractor."

**RECITALS:**

**WHEREAS**, District desires to retain a person or firm to provide the following services \_\_\_\_\_  
\_\_\_\_\_ ; and

**WHEREAS**, Contractor warrants that it is qualified and competent to render the aforesaid services;

**NOW, THEREFORE**, for and in consideration of the agreement made, and the payments to be made by District, the parties agree to the following:

**1. SCOPE OF SERVICES:**

Contractor agrees to provide all of the services described in **Exhibit "A"** attached hereto and by this reference made a part hereof.

**2. FURNISHED SERVICES:**

The District agrees to:

- A. Guarantee access to and make provisions for the Contractor to enter upon public and private lands as required to perform their work.
- B. Make available all pertinent data and records for review.
- C. Provide general bid and contract forms and special provisions format when needed.

**3. FEES AND PAYMENT SCHEDULE:**

The fees and payment schedule for furnishing services under this Contract shall be based on the rate schedule which is attached hereto as **Exhibit "B"** and by this reference incorporated herein. Said fees shall remain in effect for the entire term of the Contract.

Contractor shall provide District with his/her/its Federal Tax I.D. number prior to submitting the first invoice.

**4. MAXIMUM COST TO DISTRICT:**

In no event will the cost to District for the services to be provided herein exceed the maximum sum of \$ \_\_\_\_\_ including direct non-salary expenses.

**5. TIME OF AGREEMENT:**

This Agreement shall commence on \_\_\_\_\_, and shall terminate on \_\_\_\_\_. Certificate(s) of Insurance must be current on day Contract commences and if scheduled to lapse prior to termination date, must be automatically updated before final payment may be made to Contractor. The final invoice must be submitted within 30 days of completion of the stated scope of services.

**6. INSURANCE:**

All required insurance coverages shall be substantiated with a certificate of insurance and must be signed by the insurer or its representative evidencing such insurance to District. The general liability policy shall be endorsed naming the MARIN COUNTY TRANSIT DISTRICT as an additional insured. The certificate(s) of insurance and required endorsement shall be furnished to the District prior to commencement of work. Each certificate shall provide for thirty (30) days advance notice to District of any cancellation in coverage. Said policies shall remain in force through the life of this Contract and shall be payable on a per occurrence basis only, except those required by paragraph 6.4. a. and b. which may be provided on a claims-made basis consistent with the criteria noted therein.

Nothing herein shall be construed as a limitation of Contractor's liability, and Contractor shall indemnify and hold the District, its employees, officers, and agents, harmless and defend the District against any and all claims, damages, losses and expense that may arise by reason of the Contractor's negligent actions or omissions. District agrees to timely notify Contractor of any negligence claim.

Failure to provide and maintain the insurance required by this Contract will constitute a material breach of the agreement. In addition to any other available remedies, District may suspend payment to the Contractor for any services provided during any time that insurance was not in effect and until such time as the Contractor provides adequate evidence that Contractor has obtained the required coverage.

A request for a waiver of any of the following insurance requirements must be set forth on **Exhibit "C"** attached hereto. A waiver must address reduced amounts of coverage or the type of coverage waived entirely.

**6.1 GENERAL LIABILITY**

The Contractor shall maintain a commercial general liability insurance policy in an amount of no less than one million dollars (\$1,000,000.00). The District shall be named as an additional insured on the commercial general liability policy and the Certificate of Insurance shall include an additional endorsement page.

(see sample form: ISO - CG 20 10 11 85).

**Insurance Reduction or Waiver of Coverage Requested (Exhibit "C")**

**6.2 AUTO LIABILITY**

Where the services to be provided under this Contract involve or require the use of any type of vehicle by Contractor in order to perform said services, Contractor shall also provide comprehensive business or commercial automobile liability coverage including non-owned and hired automobile liability in the amount of one million dollars (\$1,000,000.00).

**Insurance Reduction or Waiver of Coverage Requested (Exhibit "C")**

**6.3 WORKERS' COMPENSATION**

The Contractor acknowledges that it is aware of the provisions of the Labor Code of the State of California which requires every employer to be insured against liability for workers' compensation or to undertake self- insurance in accordance with the provisions of that Code, and it certifies that it will comply with such provisions before commencing the performance of the work under this Contract. If Contractor has employees, a copy of the certificate evidencing such insurance or a copy of the Certificate of Consent to Self-Insure shall be provided to District prior to commencement of work.

**Insurance Reduction or Waiver of Coverage Requested (Exhibit "C")**

**6.4 OTHER INSURANCES**

Contractor may be required to carry additional insurance based upon the nature of the work to be performed (scope of services). For each additional required insurance, a corresponding certificate of insurance must be provided. Claims-made policies must have a retroactive date either prior to the effective date of the Contract or the beginning of the Contract work. Claims-made coverage must extend a minimum of twelve (12) months beyond completion of Contract work or end of current Contract, whichever is later. If coverage is cancelled or non-renewed, and not replaced with another claims made policy with a retroactive date prior to the Contract effective date, the Contractor must purchase extended reporting coverage for a minimum of twelve (12) months beyond completion of Contract work. Contractor shall maintain a policy limit of not less than one million dollars (\$1,000,000) per incident, with a deductible or self-insured retention not to exceed \$2,500 unless approved by the District.

6.4.a Professional Liability Insurance..... **(check box if required)**

6.4.b Maritime Insurance..... **(check box if required)**

**7. NONDISCRIMINATORY EMPLOYMENT:**

Contractor and/or any permitted subcontractor, shall not unlawfully discriminate against any individual based on race, color, religion, nationality, sex, sexual orientation, age or condition of disability. Contractor and/or any permitted subcontractor understands and agrees that Contractor and/or any permitted subcontractor is bound by and will comply with the nondiscrimination mandates of all Federal, State and local statutes, regulations and ordinances.

**8. SUBCONTRACTING:**

The Contractor shall not subcontract nor assign any portion of the work required by this Contract without prior written approval of the District except for any subcontract work identified herein. If Contractor hires a subcontractor under this Agreement, Contractor shall require subcontractor to provide and maintain insurance coverage(s) identical to what is required of Contractor under this Agreement and shall require subcontractor to name Contractor as additional insured under this Agreement. It shall be Contractor's responsibility to collect and maintain current evidence of insurance provided by its subcontractors and shall forward to the District evidence of same.

**9. ASSIGNMENT:**

The rights, responsibilities and duties under this Contract are personal to the Contractor and may not be transferred or assigned without the express prior written consent of the District.

**10. LICENSING AND PERMITS:**

The Contractor shall maintain the appropriate licenses throughout the life of this Contract. Contractor shall also obtain any and all permits which might be required by the work to be performed herein.

**11. BOOKS OF RECORD AND AUDIT PROVISION:**

Contractor shall maintain on a current basis complete books and records relating to this Contract. Such records shall include, but not be limited to, documents supporting all bids, all income and all expenditures. The books and records shall be original entry books with a general ledger itemizing all debits and credits for the work on this Contract. In addition, Contractor shall maintain detailed payroll records including all subsistence, travel and field expenses, and canceled checks, receipts and invoices for all items. These documents and records shall be retained for at least five years from the completion of this Contract. Contractor will permit District to audit all books, accounts or records relating to this Contract or all books, accounts or records of any business entities controlled by Contractor who participated in this Contract in any way. Any audit may be conducted on Contractor's premises or, at District's option, Contractor shall provide all books and records within a maximum of fifteen (15) days upon receipt of written notice from District. Contractor shall refund any monies erroneously charged.

**12. TITLE:**

Any and all documents, information and reports concerning this project prepared by the Contractor, shall be the property of the District. The Contractor may retain reproducible copies of drawings and copies of other documents. In the event of the termination of this Contract, for any reason whatsoever, Contractor shall promptly turn over all information, writing and documents to District without exception or reservation.

**13. TERMINATION:**

- A. If the Contractor fails to provide in any manner the services required under this Contract or otherwise fails to comply with the terms of this Contract or violates any ordinance, regulation or other law which applies to its performance herein, the District may terminate this Contract by giving five (5) calendar days written notice to the party involved.
- B. The Contractor shall be excused for failure to perform services herein if such services are prevented by acts of God, strikes, labor disputes or other forces over which the Contractor has no control.
- C. Either party hereto may terminate this Contract for any reason by giving thirty (30) calendar days written notice to the other parties. Notice of termination shall be by written notice to the other parties and be sent by registered mail.
- D. In the event of termination not the fault of the Contractor, the Contractor shall be paid for services performed to the date of termination in accordance with the terms of this Contract so long as proof of required insurance is provided for the periods covered in the Contract or Amendment(s).

**14. RELATIONSHIP BETWEEN THE PARTIES:**

It is expressly understood that in the performances of the services herein, the Contractor, and the agents and employees thereof, shall act in an independent capacity and as an independent contractor and not as officers, employees or agents of the District. Contractor shall be solely responsible to pay all required taxes, including but not limited to, all withholding social security, and worker's compensation.

**15. AMENDMENT:**

This Contract may be amended or modified only by written agreement of all parties.

**16. ASSIGNMENT OF PERSONNEL:**

The Contractor shall not substitute any personnel for those specifically named in its proposal unless personnel with substantially equal or better qualifications and experience are provided, acceptable to District, as is evidenced in writing.

**17. JURISDICTION AND VENUE:**

This Contract shall be construed in accordance with the laws of the State of California and the parties hereto agree that venue shall be in Marin County, California.

**18. INDEMNIFICATION:**

To the extent permitted by law (including, without limitation, California Civil Code section 2782.8), Consultant/Contractor agrees to indemnify, defend and hold harmless Marin Transit, its officers and employees from any and all claims, demands, actions, causes of action, losses, damages, liabilities, known or unknown, and all costs and expenses, including reasonable attorneys' fees in connection with any injury or damage to persons or property to the extent arising out of any negligence, recklessness or willful misconduct of Consultant/Contractor, its officers, employees, agents, contractor, subcontractors or any officer, agent or employee thereof in relation to Consultant/Contractor's performance under this Agreement.

**19. COMPLIANCE WITH APPLICABLE LAWS:**

The Contractor shall comply with any and all Federal, State and local laws (including, but not limited to the County of Marin Nuclear Free Zone, Living Wage Ordinance, and Resolution #2005-97 of the Board of Supervisors prohibiting the offshoring of professional services involving employee/retiree medical and financial data) affecting the services covered by this Contract. Copies of any of the above-referenced local laws and resolutions may be secured from the District's contact person referenced in paragraph 20. See NOTICES below.

**20. NOTICES:**

This Contract shall be managed and administered on District's behalf by the Department Contract Manager named below. All invoices shall be submitted and approved by this Department and all notices shall be given to District at the following location:

Contract Manager:

\_\_\_\_\_  
Dept./Location:

\_\_\_\_\_

\_\_\_\_\_  
Telephone No.:

\_\_\_\_\_

Notices shall be given to Contractor at the following address:

Contractor:

\_\_\_\_\_  
Address:

\_\_\_\_\_

\_\_\_\_\_  
Telephone No.:

\_\_\_\_\_



**21. ACKNOWLEDGEMENT OF EXHIBITS**

**CONTRACTOR'S INITIALS**

- EXHIBIT A.**            **Scope of Services**  
\_\_\_\_\_
  
- EXHIBIT B.**            **Fees and Payment**  
\_\_\_\_\_
  
- EXHIBIT C.**            **Insurance Reduction/Waiver**  
\_\_\_\_\_

**IN WITNESS WHEREOF**, the parties have executed this Contract on the date first above written.

**APPROVED BY**

**MARIN COUNTY TRANSIT DISTRICT:**

By: \_\_\_\_\_

**PRESIDENT, Board of Directors**

**CONTRACTOR:**

By: \_\_\_\_\_

Name: \_\_\_\_\_

Telephone No.: \_\_\_\_\_



**COUNTY COUNSEL REVIEW AND APPROVAL** (Only required if any of the noted reasons applies)

**REASON(S) FOR REVIEW:**

- Contract requires approval of the Marin County Transit District Board of Directors**
- Standard Short Form content has been modified**
- Optional review by County Counsel at Department's request**

County Counsel: \_\_\_\_\_

Date: \_\_\_\_\_

**EXHIBIT "A"**

**SCOPE OF SERVICES (required)**

**EXHIBIT "B"**

**FEES AND PAYMENT SCHEDULE (required)**

**EXHIBIT "C"**

**INSURANCE REDUCTION/WAIVER (if applicable)**

CONTRACTOR: \_\_\_\_\_

CONTRACT TITLE: \_\_\_\_\_

This statement shall accompany all requests for a reduction/waiver of insurance requirements. Please check the box if a waiver is requested or fill in the reduced coverage(s) where indicated below:

	<i>Check Where Applicable</i>	<i>Requested Limit Amount</i>	<i>CAO Use Only</i>
<b>General Liability Insurance</b>	<input type="checkbox"/>	\$	
<b>Automobile Liability Insurance</b>	<input type="checkbox"/>	\$	
<b>Workers' Compensation Insurance</b>	<input type="checkbox"/>		
<b>Professional Liability Deductible</b>	<input type="checkbox"/>	\$	

Please set forth the reasons for the requested reductions or waiver.

Contract Manager Signature: \_\_\_\_\_

Date: \_\_\_\_\_

Extension: \_\_\_\_\_

Approved by Risk Manager: \_\_\_\_\_

Date: \_\_\_\_\_



## **IX. Appendix B: FTA Grant Contract Provisions (Services)**

The FTA Grant Contract Provisions set forth herein shall be incorporated into and become part of the contemplated contract documents executed in connection with an award of this contract to the CONTRACTOR. In case of any conflict or discrepancy, the FTA Grant Contract Provisions set forth herein shall prevail over all other terms and conditions contained in the RFP, the contents of the successful proposal and/or the Professional Services Agreement.

### Energy Conservation

The contractor agrees to comply with mandatory standards and policies relating to energy efficiency, which are contained in the state energy conservation plan issued in compliance with the Energy Policy and Conservation Act.

### No Obligation by the Federal Government

The Purchaser and Contractor acknowledge and agree that, notwithstanding any concurrence by the Federal Government in or approval of the solicitation or award of the underlying contract, absent the express written consent by the Federal Government, the Federal Government is not a party to this contract and shall not be subject to any obligations or liabilities to the Purchaser, Contractor, or any other party (whether or not a party to that contract) pertaining to any matter resulting from the underlying contract.

The Contractor agrees to include the above clause in each subcontract financed in whole or in part with Federal assistance provided by FTA. It is further agreed that the clause shall not be modified, except to identify the subcontractor who will be subject to its provisions.

### Program Fraud and False or Fraudulent Statements or Related Acts

(1) The Contractor acknowledges that the provisions of the Program Fraud Civil Remedies Act of 1986, as amended, 31 U.S.C. § § 3801 et seq. and U.S. DOT regulations, "Program Fraud Civil Remedies," 49 C.F.R. Part 31, apply to its actions pertaining to this Project. Upon execution of the underlying contract, the Contractor certifies or affirms the truthfulness and accuracy of any statement it has made, it makes, it may make, or causes to be made, pertaining to the underlying contract or the FTA assisted project for which this contract work is being performed. In addition to other penalties that may be applicable, the Contractor further acknowledges that if it makes, or causes to be made, a false, fictitious, or fraudulent claim, statement, submission, or certification, the Federal Government reserves the right to impose the penalties of the Program Fraud Civil Remedies Act of 1986 on the Contractor to the extent the Federal Government deems appropriate.

(2) The Contractor also acknowledges that if it makes, or causes to be made, a false, fictitious, or fraudulent claim, statement, submission, or certification to the Federal Government under a contract connected with a project that is financed in whole or in part with Federal assistance originally awarded by FTA under the authority of 49 U.S.C. § 5307, the Government reserves the right to impose

the penalties of 18 U.S.C. § 1001 and 49 U.S.C. § 5307(n)(1) on the Contractor, to the extent the Federal Government deems appropriate.

(3) The Contractor agrees to include the above two clauses in each subcontract financed in whole or in part with Federal assistance provided by FTA. It is further agreed that the clauses shall not be modified, except to identify the subcontractor who will be subject to the provisions.

### Civil Rights

The following requirements apply to the underlying contract:

(1) Nondiscrimination - In accordance with Title VI of the Civil Rights Act, as amended, 42 U.S.C. § 2000d, section 303 of the Age Discrimination Act of 1975, as amended, 42 U.S.C. § 6102, section 202 of the Americans with Disabilities Act of 1990, 42 U.S.C. § 12132, and Federal transit law at 49 U.S.C. § 5332, the Contractor agrees that it will not discriminate against any employee or applicant for employment because of race, color, creed, national origin, sex, age, or disability. In addition, the Contractor agrees to comply with applicable Federal implementing regulations and other implementing requirements FTA may issue.

(2) Equal Employment Opportunity - The following equal employment opportunity requirements apply to the underlying contract:

(a) Race, Color, Creed, National Origin, Sex - In accordance with Title VII of the Civil Rights Act, as amended, 42 U.S.C. § 2000e, and Federal transit laws at 49 U.S.C. § 5332, the Contractor agrees to comply with all applicable equal employment opportunity requirements of U.S. Department of Labor (U.S. DOL) regulations, "Office of Federal Contract Compliance Programs, Equal Employment Opportunity, Department of Labor," 41 C.F.R. Parts 60 et seq., (which implement Executive Order No. 11246, "Equal Employment Opportunity," as amended by Executive Order No. 11375, "Amending Executive Order 11246 Relating to Equal Employment Opportunity," 42 U.S.C. § 2000e note), and with any applicable Federal statutes, executive orders, regulations, and Federal policies that may in the future affect construction activities undertaken in the course of the Project. The Contractor agrees to take affirmative action to ensure that applicants are employed, and that employees are treated during employment, without regard to their race, color, creed, national origin, sex, or age. Such action shall include, but not be limited to, the following: employment, upgrading, demotion or transfer, recruitment or recruitment advertising, layoff or termination; rates of pay or other forms of compensation; and selection for training, including apprenticeship. In addition, the Contractor agrees to comply with any implementing requirements FTA may issue.

(b) Age - In accordance with section 4 of the Age Discrimination in Employment Act of 1967, as amended, 29 U.S.C. § 623 and Federal transit law at 49 U.S.C. § 5332, the Contractor agrees to refrain from discrimination against present and prospective employees for reason of age. In addition, the Contractor agrees to comply with any implementing requirements FTA may issue.

(c) Disabilities - In accordance with section 102 of the Americans with Disabilities Act, as amended, 42 U.S.C. § 12112, the Contractor agrees that it will comply with the requirements of U.S. Equal

Employment Opportunity Commission, "Regulations to Implement the Equal Employment Provisions of the Americans with Disabilities Act," 29 C.F.R. Part 1630, pertaining to employment of persons with disabilities. In addition, the Contractor agrees to comply with any implementing requirements FTA may issue.

(3) The Contractor also agrees to include these requirements in each subcontract financed in whole or in part with Federal assistance provided by FTA, modified only if necessary to identify the affected parties.

#### Incorporation of Federal Transit Administration (FTA) Terms

The preceding provisions include, in part, certain Standard Terms and Conditions required by DOT, whether or not expressly set forth in the preceding contract provisions. All contractual provisions required by DOT, as set forth in FTA Circular 4220.1E are hereby incorporated by reference. Anything to the contrary herein notwithstanding, all FTA mandated terms shall be deemed to control in the event of a conflict with other provisions contained in this Agreement. The Contractor shall not perform any act, fail to perform any act, or refuse to comply with any Marin Transit requests that would cause Marin Transit to be in violation of the FTA terms and conditions.

#### Federal Changes

Contractor shall at all times comply with all applicable FTA regulations, policies, procedures and directives, including without limitation those listed directly or by reference in the Master Agreement between Purchaser and FTA, as they may be amended or promulgated from time to time during the term of this contract. Contractor's failure to so comply shall constitute a material breach of this contract.

#### Contracts Involving Federal Privacy Act Requirements

(1) The Contractor agrees to comply with, and assures the compliance of its employees with, the information restrictions and other applicable requirements of the Privacy Act of 1974, 5 U.S.C. § 552a. Among other things, the Contractor agrees to obtain the express consent of the Federal Government before the Contractor or its employees operate a system of records on behalf of the Federal Government. The Contractor understands that the requirements of the Privacy Act, including the civil and criminal penalties for violation of that Act, apply to those individuals involved, and that failure to comply with the terms of the Privacy Act may result in termination of the underlying contract.

(2) The Contractor also agrees to include these requirements in each subcontract to administer any system of records on behalf of the Federal Government financed in whole or in part with Federal assistance provided by FTA.

#### Suspension and Debarment



This contract is a covered transaction for purposes of 49 CFR Part 29. As such, the contractor is required to verify that none of the contractor, its principals, as defined at 49 CFR 29.995, or affiliates, as defined at 49 CFR 29.905, are excluded or disqualified as defined at 49 CFR 29.940 and 29.945.

The contractor is required to comply with 49 CFR 29, Subpart C and must include the requirement to comply with 49 CFR 29, Subpart C in any lower tier covered transaction it enters into.

By signing and submitting its bid or proposal and signing the certification form included in this document, the bidder or proposer certifies as follows:

The certification in this clause is a material representation of fact relied upon by Marin Transit. If it is later determined that the bidder or proposer knowingly rendered an erroneous certification, in addition to remedies available to Marin Transit, the Federal Government may pursue available remedies, including but not limited to suspension and/or debarment. The bidder or proposer agrees to comply with the requirements of 49 CFR 29, Subpart C while this offer is valid and throughout the period of any contract that may arise from this offer. The bidder or proposer further agrees to include a provision requiring such compliance in its lower tier covered transactions.

#### Access to Records

The following access to records requirements apply to this Contract:

- 1) Where the Purchaser is not a State but a local government and is the FTA Marin Transit or a subgrantee of the FTA Marin Transit in accordance with 49 C. F. R. 18.36(i), the Contractor agrees to provide the Purchaser, the FTA Administrator, the Comptroller General of the United States or any of their authorized representatives access to any books, documents, papers and records of the Contractor which are directly pertinent to this contract for the purposes of making audits, examinations, excerpts and transcriptions. Contractor also agrees, pursuant to 49 C. F. R. 633.17 to provide the FTA Administrator or his authorized representatives including any PMO Contractor access to Contractor's records and construction sites pertaining to a major capital project, defined at 49 U.S.C. 5302(a)1, which is receiving federal financial assistance through the programs described at 49 U.S.C. 5307, 5309 or 5311.
- 2) Where the Purchaser is a State and is the FTA Marin Transit or a subgrantee of the FTA Marin Transit in accordance with 49 C.F.R. 633.17, Contractor agrees to provide the Purchaser, the FTA Administrator or his authorized representatives, including any PMO Contractor, access to the Contractor's records and construction sites pertaining to a major capital project, defined at 49 U.S.C. 5302(a)1, which is receiving federal financial assistance through the programs described at 49 U.S.C. 5307, 5309 or 5311. By definition, a major capital project excludes contracts of less than the simplified acquisition threshold currently set at \$100,000.
- 3) Where the Purchaser enters into a negotiated contract for other than a small purchase or under the simplified acquisition threshold and is an institution of higher education, a hospital or other non-profit organization and is the FTA Marin Transit or a subgrantee of the FTA Marin Transit in accordance with 49 C.F.R. 19.48, Contractor agrees to provide the Purchaser, FTA

Administrator, the Comptroller General of the United States or any of their duly authorized representatives with access to any books, documents, papers and record of the Contractor which are directly pertinent to this contract for the purposes of making audits, examinations, excerpts and transcriptions.

- 4) Where any Purchaser which is the FTA Marin Transit or a subgrantee of the FTA Marin Transit in accordance with 49 U.S.C. 5325(a) enters into a contract for a capital project or improvement (defined at 49 U.S.C. 5302(a)1) through other than competitive bidding, the Contractor shall make available records related to the contract to the Purchaser, the Secretary of Transportation and the Comptroller General or any authorized officer or employee of any of them for the purposes of conducting an audit and inspection.
- 5) The Contractor agrees to permit any of the foregoing parties to reproduce by any means whatsoever or to copy excerpts and transcriptions as reasonably needed.
- 6) The Contractor agrees to maintain all books, records, accounts and reports required under this contract for a period of not less than three years after the date of termination or expiration of this contract, except in the event of litigation or settlement of claims arising from the performance of this contract, in which case Contractor agrees to maintain same until the Purchaser, the FTA Administrator, the Comptroller General, or any of their duly authorized representatives, have disposed of all such litigation, appeals, claims or exceptions related thereto. Reference 49 CFR 18.39(i)(11).
- 7) FTA does not require the inclusion of these requirements in subcontracts.

#### Termination

- 1) Termination for Convenience

Marin Transit may terminate this contract, in whole or in part, at any time by written notice to the Contractor when it is in the Government's best interest. The Contractor shall be paid its costs, including contract close-out costs, and profit on work performed up to the time of termination. The Contractor shall promptly submit its termination claim to Marin Transit to be paid to the Contractor. If the Contractor has any property in its possession belonging to Marin Transit, the Contractor will account for the same, and dispose of it in the manner Marin Transit directs.

- 2) Termination for Default

If the Contractor does not deliver supplies in accordance with the contract delivery schedule, or, if the contract is for services, the Contractor fails to perform in the manner called for in the contract, or if the Contractor fails to comply with any other provisions of the contract, Marin Transit may terminate this contract for default. Termination shall be effected by serving a notice of termination on the contractor setting forth the manner in which the Contractor is in default. The contractor will only be paid the contract price for supplies delivered and

accepted, or services performed in accordance with the manner of performance set forth in the contract.

If it is later determined by Marin Transit that the Contractor had an excusable reason for not performing, such as a strike, fire, or flood, events which are not the fault of or are beyond the control of the Contractor, Marin Transit after setting up a new delivery of performance schedule, may allow the Contractor to continue work, or treat the termination as a termination for convenience.

3) Opportunity to Cure

Marin Transit in its sole discretion may, in the case of a termination for breach or default, allow the Contractor up to 15 Days in which to cure the defect. In such case, the notice of termination will state the time period in which cure is permitted and other appropriate conditions.

If Contractor fails to remedy to Marin Transit's satisfaction the breach or default of any of the terms, covenants, or conditions of this Contract within ten (10) days after receipt by Contractor of written notice from Marin Transit setting forth the nature of said breach or default, Marin Transit shall have the right to terminate the Contract without any further obligation to Contractor. Any such termination for default shall not in any way operate to preclude Marin Transit from also pursuing all available remedies against Contractor and its sureties for said breach or default.

4) Waiver of Remedies for any Breach

In the event that Marin Transit elects to waive its remedies for any breach by Contractor of any covenant, term or condition of this Contract, such waiver by Marin Transit shall not limit Marin Transit's remedies for any succeeding breach of that or of any other term, covenant, or condition of this Contract.

5) Termination for Convenience (Professional or Transit Service Contracts)

Marin Transit, by written notice, may terminate this contract, in whole or in part, when it is in the Government's interest. If this contract is terminated, the Marin Transit shall be liable only for payment under the payment provisions of this contract for services rendered before the effective date of termination.

6) Termination for Default (Supplies and Service)

If the Contractor fails to deliver supplies or to perform the services within the time specified in this contract or any extension or if the Contractor fails to comply with any other provisions of this contract, Marin Transit may terminate this contract for default. Marin Transit shall terminate by delivering to the Contractor a Notice of Termination specifying the nature of the default. The Contractor will only be paid the contract price for supplies delivered and

accepted, or services performed in accordance with the manner or performance set forth in this contract.

If, after termination for failure to fulfill contract obligations, it is determined that the Contractor was not in default, the rights and obligations of the parties shall be the same as if the termination had been issued for the convenience of the Marin Transit.

#### 7) Termination for Convenience of Default (Cost-Type Contracts)

Marin Transit may terminate this contract, or any portion of it, by serving a notice of termination on the Contractor. The notice shall state whether the termination is for convenience of Marin Transit or for the default of the Contractor. If the termination is for default, the notice shall state the manner in which the contractor has failed to perform the requirements of the contract. The Contractor shall account for any property in its possession paid for from funds received from Marin Transit, or property supplied to the Contractor by Marin Transit. If the termination is for default, Marin Transit may fix the fee, if the contract provides for a fee, to be paid the contractor in proportion to the value, if any, of work performed up to the time of termination. The Contractor shall promptly submit its termination claim to Marin Transit and the parties shall negotiate the termination settlement to be paid the Contractor.

If the termination is for the convenience of Marin Transit, the Contractor shall be paid its contract close-out costs, and a fee, if the contract provided for payment of a fee, in proportion to the work performed up to the time of termination.

If, after serving a notice of termination for default, Marin Transit determines that the Contractor has an excusable reason for not performing, such as strike, fire, flood, events which are not the fault of and are beyond the control of the contractor, Marin Transit, after setting up a new work schedule, may allow the Contractor to continue work, or treat the termination as a termination for convenience.

#### Disadvantaged Business Enterprises

(1) This contract is subject to the requirements of Title 49, Code of Federal Regulations, Part 26, Participation by Disadvantaged Business Enterprises in Department of Transportation Financial Assistance Programs. The national goal for participation of Disadvantaged Business Enterprises (DBE) is 10%. The agency's overall goal for DBE participation is 2.9%. A separate contract goal has not been established for this RFP.

(2) The contractor shall not discriminate on the basis of race, color, national origin, or sex in the performance of this contract. The contractor shall carry out applicable requirements of 49 CFR Part 26 in the award and administration of this DOT-assisted contract. Failure by the contractor to carry out these requirements is a material breach of this contract, which may result in the termination of this contract or such other remedy as Marin Transit deems appropriate. Each subcontract the contractor signs with a subcontractor must include the assurance in this paragraph (see 49 CFR 26.13(b)).

- (3) The successful bidder/offeror will be required to report its DBE participation obtained through race-neutral means throughout the period of performance.
- (4) The contractor is required to pay its subcontractors performing work related to this contract for satisfactory performance of that work no later than 30 days after the contractor's receipt of payment for that work from Marin Transit. In addition, the contractor is required to return any retainage payments to those subcontractors within 30 days after incremental acceptance of the subcontractor's work by Marin Transit and contractor's receipt of the partial retainage payment related to the subcontractor's work.
- (5) The contractor must promptly notify Marin Transit whenever a DBE subcontractor performing work related to this contract is terminated or fails to complete its work, and must make good faith efforts to engage another DBE subcontractor to perform at least the same amount of work. The contractor may not terminate any DBE subcontractor and perform that work through its own forces or those of an affiliate without prior written consent of Marin Transit.
- (6) Marin Transit encourages prime contractors to use financial institutions owned and controlled by socially and economically disadvantaged individuals. If available, institutions located in Marin County are preferred.
- (7) Marin Transit is a participant in the California Unified Certification Program (CUCP), which follows U.S. DOT directives and guidance concerning certification matters. The CUCP makes all DBE certification decisions on behalf of U.S. DOT Marin Transits in the state. Marin Transit relies upon the CUCP for the certification of DBE firms and ensures that only firms certified as eligible DBEs participate in the Program. The DBE Database is a consolidated and automated directory that identifies firms that have been certified as DBEs by the CUCP. This database is available at Caltrans' website, [www.dot.ca.gov/hq/bep/find\\_certified.htm](http://www.dot.ca.gov/hq/bep/find_certified.htm). The DBE Database shall not in any way prequalify the identified DBE firms with respect to licensing, bondability, competence, or financial responsibility.
- (8) A DBE is a for-profit, small business concern; 1) that is at least fifty-one percent (51%) owned by one or more individuals who are both socially and economically disadvantaged, or, in the case of a corporation, in which fifty-one percent (51%) of the stock is owned by one or more socially and economically disadvantaged individuals; and 2) whose management and daily business operations are controlled by one or more of the socially and economically disadvantaged individuals who own it. With respect to firms participating as DBEs in U.S. DOT assisted contracts, a small business concern is an existing small business, as defined by Section 3 of the Small Business Act and the Small Business Administration regulations implementing it (13 CFR Part 121), whose average annual gross receipts for the previous three (3) years does not exceed \$22.41 million (or as adjusted for inflation by the Secretary of U.S. DOT) pursuant to 49 CFR § 26.65(b).
- (9) Marin Transit shall monitor and track the actual DBE participation through contractor and subcontractor reports of payments. The District's Civil Rights Officer will maintain a running tally of payments actually made to DBE firms and may require prime contractors and DBE subcontractors and suppliers to provide appropriate documentation to verify such payments. Marin Transit will monitor actual DBE participation and will include a written certification that Marin Transit has reviewed

contracting records and monitored work sites in California for this purpose. DBE participation will be counted in accordance with the federal regulations. Credit toward overall or contract goals, if applicable, will only be given upon satisfactory evidence that payments were actually made to DBEs.

(10) The contractor shall maintain records of all DBE participation in the performance of the contract, including subcontracts entered into with certified DBEs and all materials purchased from certified DBEs. It is the contractor's responsibility to maintain records and documents for three (3) years following the performance of the contract. These records will be made available for inspection upon request by any authorized representative of Marin Transit or U.S. DOT. This reporting requirement is also extended to any certified DBE subcontractor. Marin Transit will maintain a running tally of payments actually made to DBE firms and may require prime contractors and DBE subcontractors and suppliers to provide appropriate documentation to verify such payments. Credit toward overall or contract goals will only be given upon satisfactory evidence that payments were actually made to DBEs. Marin Transit may perform interim audits of contract payments to DBEs. The audit will review payments to DBE subcontractors to ensure that the actual amount paid to DBE subcontractors equals or exceeds the dollar amounts stated in the report of proposed DBE participation.

## **X. Appendix C: FTA Certification Forms**

- Certification Regarding Debarment, Suspension, Ineligibility and Voluntary Exclusion
- Subcontractor's Listing Form
- Schedule of DBE

CERTIFICATION REGARDING DEBARMENT,  
SUSPENSION, INELIGIBILITY AND VOLUNTARY EXCLUSION

(Pursuant to 49 CFR Part 29, Appendix B)

- A. By signing and submitting this proposal, the Proposer is providing the signed certification set out below.
1. The certification in this clause is a material representation of fact upon which reliance was placed when this transaction was entered into. If it is later determined that the prospective lower tier participant knowingly rendered an erroneous certification, in addition to other remedies available to the Federal Government, the department or agency with which this transaction originated may pursue available remedies, including suspension and/or debarment.
  2. The Proposer shall provide immediate written notice to MARIN TRANSIT if at any time the Proposer learns that its certification was erroneous when submitted or has become erroneous by reason of changed circumstances.
  3. The terms “covered transaction,” “debarred,” “suspended,” “ineligible,” “lower tier covered transaction,” “participant,” “person,” “primary covered transaction,” “principal,” “proposal,” and “voluntarily excluded,” as used in this clause, have the meanings set out in the Definitions and Coverage sections of rules implementing Executive Order 12549 (49 CFR Part 29). You may contact MARIN TRANSIT for assistance in obtaining a copy of those regulations.
  4. The Proposer agrees by submitting this proposal that, should the proposed covered transaction be entered into, it shall not knowingly enter into any lower tier covered transaction with a person who is proposed for debarment under 48 CFR part 9, subpart 9.4, debarred, suspended, declared ineligible, or voluntarily excluded from participation in this covered transaction, unless authorized in writing by the department or agency with which this transaction originated.
  5. The Proposer further agrees by submitting this proposal that it will include the clause entitled “Certification Regarding Debarment, Suspension, Ineligibility and Voluntary Exclusion”, as set out below in Subsection (B), in all subcontracts and in all solicitations for lower tier covered transactions as modified to identify the subcontractor.



6. A participant in a covered transaction may rely upon a certification of a prospective participant in a lower tier covered transaction that it is not debarred, suspended, ineligible, or voluntarily excluded from the covered transaction, unless it knows that the certification is erroneous. A participant may decide the method and frequency by which it determines the eligibility of its principals. Each participant may, but is not required to, check the Non-procurement List issued by U.S. General Service Administration.
7. Nothing contained in the foregoing shall be construed to require establishment of system of records in order to render in good faith the certification required by this clause. The knowledge and information of a participant is not required to exceed that which is normally possessed by a prudent person in the ordinary course of business dealings.
8. Except for transactions authorized under Paragraph 4 of these instructions, if a participant in a covered transaction knowingly enters into a lower tier covered transaction with a person who is proposed for debarment under 48 CFR part 9, subpart 9.4, suspended, debarred, ineligible, or voluntarily excluded from participation in this transaction, in addition to all remedies available to the Federal Government, the department or agency with which this transaction originated may pursue available remedies including suspension and/or debarment.

**B. Certification Regarding Debarment, Suspension, Ineligibility and Voluntary Exclusion - Lower Tier Covered Transaction**

1. The Proposer certifies, by submission of this bid or proposal, that neither it nor its "principals," as defined at 49 C.F.R. § 29.105(p), is presently debarred, suspended, proposed for debarment, declared ineligible, or voluntarily excluded from participation in this transaction by any Federal department or agency.
2. If Proposer is unable to certify to the statements in this certification, Proposer shall attach an explanation to this proposal.

Date: \_\_\_\_\_

Name of Proposer: \_\_\_\_\_

Signature: \_\_\_\_\_

Print Name/Title: \_\_\_\_\_

**SUBCONTRACTORS' LISTING FORM**

This form is in compliance with Sections 4100 – 4113, inclusive, of the California Public Contracts Code. Each Bidder shall list all subcontractors that will perform work, provide labor or render services to the Bidder in connection with the Project in an amount in excess of one-half of 1 percent of the prime contractor's total bid or ten thousand dollars (\$10,000), whichever is greater.

Attach additional copies of this form, if necessary.

SUBCONTRACTOR		ESTIMATED DOLLAR AMOUNT OF SUBCONTRACT	DESCRIPTION OF WORK	DBE OWNED BUSINESS
Name				
Address				
Phone				
Fax				
Email				
Name				
Address				
Phone				
Fax				
Email				
Name				
Address				
Phone				
Fax				
Email				

NAME OF FIRM: \_\_\_\_\_

AUTHORIZED SIGNATURE: \_\_\_\_\_

PRINT NAME: \_\_\_\_\_

TITLE OF PERSON SIGNING: \_\_\_\_\_

DATE: \_\_\_\_\_

## SCHEDULE OF DBE

---

Name of Prime Contractor

Name of DBE	Street Address	City, State, Zip	Type of Work	Start/End Dates	Agreed Price

The undersigned will enter into a formal agreement with Disadvantaged Contractors for work listed in this schedule conditioned upon the execution of a contract Marin Transit.

---

Name of Prime Contractor (*signature*)

\_\_\_\_\_

Date

**XI. Appendix D: California Levine Act Statement**

California Government Code § 84308

**CALIFORNIA LEVINE ACT STATEMENT**

California Government Code § 84308, commonly referred to as the “Levine Act,” precludes an officer of a local government agency from participating in the award of a contract if he or she receives any political contributions totaling more than \$250 in the 12 months preceding the pendency of the contract award, and for three months following the final decision, from the person or company awarded the contract. This prohibition applies to contributions to the officer, or received by the officer on behalf of any other officer, or on behalf of any candidate for office or on behalf of any committee.

Marin Transit’s Board of Directors Include:

Judy Arnold
Kathrin Sears
Madeline Kellner
Susan L. Adams
Katie Rice
Steve Kinsey
Stephanie Moulton-Peters
Kate Colin (alt)

1. Have you or your company, or any agent on behalf of you or your company, made any political contributions of more than \$250 to any Marin Transit Board Member in the 12 months preceding the date of the issuance of this request for qualifications?

\_\_\_ YES\_\_\_ NO

If yes, please identify the director: \_\_\_\_\_

2. Do you or your company, or any agency on behalf of you or your company, anticipate or plan to make any political contributions of more than \$250 to any Marin Transit director in the three months following the award of the contract?

\_\_\_ YES\_\_\_ NO

If yes, please identify the director: \_\_\_\_\_

Answering yes to either of the two questions above does not preclude Marin Transit from awarding a contract to your firm. It does, however, preclude the identified director(s) from participating in the contract award process for this contract.

\_\_\_\_\_  
DATE

\_\_\_\_\_  
(SIGNATURE OF AUTHORIZED OFFICIAL)

\_\_\_\_\_  
(TYPE OR WRITE APPROPRIATE NAME, TITLE)

\_\_\_\_\_  
(TYPE OR WRITE NAME OF COMPANY)

## **XII. Appendix E: Project Location and Exhibit of Improvements**

Project locations are attached.

Exhibit of Improvements can be downloaded at [www.marintransit.org/purchasing](http://www.marintransit.org/purchasing)



CAD USER: jeden

PLOT DATE: Nov 09 2017 - 11:33:32am

























FILE NAME: 02-Marin Transit Bus Stops - GN-1

PATH: \\valued1\Projects\Marin Transit-CC-17104-On-Call\GES\CADD\Sheets

**STANDARD ABBREVIATIONS**

AB	AGGREGATE BASE	LIP	LIP OF GUTTER
AC	ASPHALT CONCRETE	MAX.	MAXIMUM
AP	ANGLE POINT	MH	MANHOLE
APPROX	APPROXIMATE	MIN	MINIMUM
ATT	AT&T	MCTD	MARIN COUNTY TRANSIT DISTRICT
BC	BEGIN HORIZONTAL CURVE	MMD	MARIN MUNICIPAL WATER DISTRICT
BLDG	BUILDING	NO	NUMBER
BOW	BACK OF WALK	NTS	NOT TO SCALE
CCU	CENTRAL CONTROL UNIT	PGE	PACIFIC GAS AND ELECTRIC
C&G	CURB AND GUTTER	PCC	PORTLAND CEMENT CONCRETE
CB	CATCH BASIN	PRC	POINT OF REVERSE CURVE
CL	CLASS	PVC	POLYVINYL CHLORIDE PIPE
CONC	CONCRETE	R	RADIUS
CONT	CONTINUOUS	RCP	REINFORCED CONCRETE PIPE
DET	DETAIL	RVFD	ROSS VALLEY FIRE DEPARTMENT
DI	DRAINAGE INLET	RVSD	ROSS VALLEY SANITARY DISTRICT
DIA	DIAMETER	R/W	RIGHT OF WAY
DWG	DRAWING	RW	RETAINING WALL
DWY	DRIVEWAY	SAW	SAWCUT
EC	END HORIZONTAL CURVE	SD	STORM DRAIN
EG	EXISTING GROUND	SF	SQUARE FOOT
EP	EXISTING PAVEMENT	SHLD	SHOULDER
EX	EXISTING	SL	STREET LIGHT
FL	FLOW LINE	SS	SANITARY SEWER
FL	EXPANSION JOINT	STD	STANDARD
FH	FIRE HYDRANT	SWLK	SIDEWALK
FOC	FACE OF CURB	TC	TOP OF CURB
FOW	FRONT OF WALK	TEMP	TEMPORARY
GGBHTD	GOLDEN GATE BRIDGE, HIGHWAY AND TRANSPORTATION DISTRICT	TS	TRAFFIC SIGNAL
HMA	HOT MIX ASPHALT	TV	CABLE TV
LED	LIGHT EMITTING DIODE	UC	UNIFORM CONSTRUCTION STANDARDS
LF	LINEAR FOOT	WM	WATER METER
		WV	WATER VALVE

**LEGEND**

EXISTING	DESCRIPTION	PROPOSED
---	RIGHT OF WAY/ PROPERTY LINE	---
----	CURB	====
----	EDGE OF PAVEMENT/ LIP OF GUTTER	----
----	FENCE	----
----	SAWCUT LINE	----
----	CONFORM TO EXISTING	----
	TREE	
	STREET SIGN	
	MANHOLE	
	FIRE HYDRANT	
	VALVE	
	UTILITY VAULT/BOX	
(XX.XX)	ELEVATION	XX.XX
	UTILITY POLE	
	STREET LIGHT	
	5' WIDE BY 8' LENGTH (MIN) CLEAR SPACE	
	BUS SHELTER AND BENCH	
	TRASH RECEPTACLE	
	PEDESTRIAN BENCH	
	TEMPORARY INLET PROTECTION	

**GENERAL NOTES**

- THESE PLANS SHALL BE USED IN CONJUNCTION WITH THE CONTRACT SPECIAL PROVISIONS, THE LATEST EDITION OF THE UNIFORM CONSTRUCTION STANDARDS FOR ALL CITIES AND COUNTY OF MARIN, AND THE LATEST EDITION OF THE STATE OF CALIFORNIA DEPARTMENT OF TRANSPORTATION (CALTRANS) STANDARD PLANS AND STANDARD SPECIFICATIONS.
- THE CONTRACTOR SHALL INSPECT THE PROJECT SITES PRIOR TO SUBMITTING A BID IN ORDER TO OBSERVE AND DETERMINE THE EXISTING JOB SITE CONDITIONS.
- THE CONTRACTOR AGREES THAT IN ACCORDANCE WITH GENERALLY ACCEPTED CONSTRUCTION PRACTICES, CONTRACTOR SHALL ASSUME COMPLETE RESPONSIBILITY FOR JOB SITE CONDITIONS DURING THE COURSE OF CONSTRUCTION OF THE PROJECT. THESE PLANS DO NOT INCLUDE COMPONENTS NECESSARY FOR CONSTRUCTION SAFETY. IT IS THE CONTRACTOR'S RESPONSIBILITY TO PROVIDE FOR THE SAFETY OF ALL PERSONS AND PROPERTY DURING THE COURSE OF THE PROJECT AND TO COMPLY WITH CONSTRUCTION SAFETY ORDERS AND CAL/OSHA REQUIREMENTS. THESE REQUIREMENTS SHALL APPLY CONTINUOUSLY AND NOT BE LIMITED TO NORMAL WORKING HOURS.
- NO EFFORT HAS BEEN MADE TO VERIFY THE LOCATION OF EXISTING UNDERGROUND UTILITIES AND ALL IMPROVEMENTS MAY NOT BE SHOWN. CONTRACTOR SHALL NOTIFY UNDERGROUND SERVICE ALERT (U.S.A.) AT (800) 227-2600 OR 811 A MINIMUM OF 48 HOURS IN ADVANCE OF ANY EXCAVATION. ANY ADDITIONAL COSTS INCURRED AS A RESULT OF CONTRACTOR'S FAILURE TO VERIFY LOCATION OF EXISTING UTILITIES PRIOR TO BEGINNING OF CONSTRUCTION SHALL BE BORNE BY THE CONTRACTOR.
- TRAFFIC CONTROL DURING CONSTRUCTION SHALL BE THE CONTRACTOR'S RESPONSIBILITY. ALL TRAFFIC CONTROL AND DEVICES SHALL BE IN ACCORDANCE WITH THE LATEST EDITION OF THE "CALIFORNIA MANUAL OF UNIFORM TRAFFIC CONTROL DEVICES" (MUTCD) ISSUED BY CALTRANS.
- THE CONTRACTOR SHALL PROVIDE FOR CONTINUOUS VEHICULAR AND PEDESTRIAN INGRESS AND EGRESS TO ALL PRIVATE PROPERTY ADJACENT TO THE WORK THROUGHOUT THE PERIOD OF CONSTRUCTION UNLESS APPROVED IN ADVANCE BY THE ENGINEER.
- THE CONTRACTOR SHALL BE RESPONSIBLE FOR ANY DAMAGES TO THE SITE OR THE SURROUNDING AREA AS A RESULT OF THE CONTRACTOR'S WORK OR OPERATIONS. EXISTING FACILITIES THAT ARE DAMAGED OR DISPLACED BY THE CONTRACTOR SHALL BE REPLACED AT THE CONTRACTOR'S EXPENSE.
- IF, DURING THE COURSE OF THE WORK, THE CONTRACTOR ENCOUNTERS ANY SURFACE OR SUBSURFACE MATERIALS THAT THEY BELIEVE ARE HAZARDOUS (AS DEFINED IN SECT. 25117 OF THE HEALTH AND SAFETY CODE), THE CONTRACTOR MUST INFORM THE ENGINEER IN WRITING IMMEDIATELY. MATERIAL IS TO REMAIN UNDISTURBED UNTIL AN INVESTIGATION BY THE TOWN. REMOVAL AND/OR DISPOSAL OF HAZARDOUS MATERIALS IS NOT PART OF THE SCOPE OF WORK.
- THE PRIME CONTRACTOR AND ALL SUBCONTRACTORS SHALL BE APPROPRIATELY LICENSED BY THE CALIFORNIA CONTRACTORS STATE LICENSE BOARD.
- CONTRACTOR SHALL PROTECT ALL MONUMENTS AND ADJUST COVERS TO GRADE AT LOCATIONS SHOWN ON THE PLANS. MONUMENTS TO BE DISTURBED SHALL BE IDENTIFIED BY THE CONTRACTOR TO THE ENGINEER PRIOR TO DISRUPTION SO THAT A CONTRACTOR-HIRED SURVEYOR CAN SET REFERENCE POINTS TO RE-ESTABLISH THE MONUMENT UPON COMPLETION OF THE WORK.

**EROSION CONTROL NOTES**

- THE EROSION AND SEDIMENT CONTROL MEASURES WILL BE OPERABLE DURING THE RAINY SEASON, OCTOBER 1ST TO APRIL 15TH. NO GRADING WILL OCCUR BETWEEN OCTOBER 15TH AND APRIL 15TH, UNLESS AUTHORIZED BY THE ENGINEER.
- CHANGES TO THIS STORM WATER POLLUTION PREVENTION PLAN TO MEET FIELD CONDITIONS WILL BE MADE ONLY WITH THE APPROVAL OF, OR AT THE DIRECTION OF THE OWNER. CHANGES MADE TO SUIT FIELD CONDITIONS SHALL BE BROUGHT TO THE IMMEDIATE ATTENTION OF THE ENGINEER.
- DURING THE RAINY SEASON, ALL PAVED AREAS WILL BE KEPT CLEAR OF EARTH MATERIAL AND DEBRIS. THE SITE WILL BE MAINTAINED SO THAT A MINIMUM OF SEDIMENT-LADEN RUNOFF ENTERS THE STORM DRAIN SYSTEM. THESE PLANS SHALL REMAIN IN EFFECT UNTIL THE TRACT IMPROVEMENTS ARE ACCEPTED BY MCTD, AND ALL SLOPES ARE STABILIZED FROM EROSION.
- THIS PLAN ASSUMES THE COMPLETION OF GRADING AND STORM DRAIN FACILITIES. IF FACILITIES ARE NOT COMPLETED, CONTACT THE ENGINEER FOR PLAN REVISIONS.



**POLLUTION CONTROL NOTES**

- NO EXPORT OF SOIL IS ANTICIPATED.
- IF SIGNIFICANT SEDIMENT OR OTHER VISUAL SYMPTOMS OF IMPURITIES ARE NOTICED IN THE STORM WATER, CONTACT THE ENGINEER IMMEDIATELY.
- CONTRACTOR IS RESPONSIBLE FOR INSPECTION AND RESTORATION OF ALL ASPECTS OF THIS PLAN. SEDIMENT ON SIDEWALKS AND GUTTERS SHALL BE REMOVED BY SHOVEL OR BROOM AND PLACED IN REAR LOT OR OTHER STOCKPILES.
- CATCH BASIN TOPS SHALL BE STAMPED TO READ "NO DUMPING - FLOWS TO BAY."
- ALL DUMPSTERS OR OTHER TRASH STORAGE ENCLOSURES SHALL BE UTILIZED SOLELY FOR NON-HAZARDOUS MATERIALS PER SWPPP SEC 3.
- ALL EMPLOYEES, CONTRACTORS, AND SUBCONTRACTORS ARE RESPONSIBLE FOR CONFORMING TO THE ELEMENTS SHOWN ON THIS PLAN OR RELATED DOCUMENTS. ANY CONTRACTOR PLANNING TO DO WORK ON-SITE SHALL BE RESPONSIBLE FOR OBTAINING AND REVIEWING ALL SWPPP INFORMATION FROM OWNER PRIOR TO START OF WORK AND EDUCATING ALL OF THEIR EMPLOYEES OR SUBCONTRACTORS AS TO THE CONTENTS OF THIS SWPPP.
- THE CONTRACTOR IS RESPONSIBLE FOR OBTAINING ALL PERMITS AND FILING ALL PLANS WITH RELATED AGENCIES ASSOCIATED WITH THEIR WORK. THIS SHALL INCLUDE, BUT NOT BE LIMITED TO, PERMITS FOR STORAGE OF HAZARDOUS MATERIALS, BUSINESS PLANS, PERMITS FOR STORAGE OF FLAMMABLE LIQUIDS, GRADING PERMITS, OR OTHER PLANS OR PERMITS REQUIRED BY MARIN COUNTY, MCTD, OR OTHER AGENCIES. ALL PROPERTY OWNERS, CONTRACTORS, OR SUBCONTRACTORS WORKING ON-SITE ARE INDIVIDUALLY RESPONSIBLE FOR OBTAINING AND SUBMITTING ANY BUSINESS PLANS OR PERMITS REQUIRED BY CITY, STATE OR LOCAL AGENCIES.
- CONTRACTOR MAY RELOCATE STORAGE, DELIVERY, OR WASH-OUT AREAS, TO SUIT THEIR OPERATIONS. RELOCATED LOCATION TO BE SHOWN ON PLANS MAINTAINED AT JOBSITE. CONTACT ENGINEER FOR ANY PLAN REVISIONS. PLAN REVISIONS SHALL BE SUBMITTED TO MCTD IF REQUESTED. CONTRACTOR TO MAINTAIN SECONDARY CONTAINMENT AS NECESSARY TO PROHIBIT POLLUTION AND TOXIC MATERIALS FROM ENTERING STORM DRAIN.
- AFTER COMPLETION OF THE CURB, GUTTER AND PAVING, THE SILT FILTERS SHALL BE MODIFIED TO BURLAP SACKS FILLED WITH 3/4" DRAIN ROCK OR OTHER ACCEPTED BMP POSITIONED SURROUNDING EACH CATCH BASIN.

**URBAN RUNOFF POLLUTION NOTES**

- STABILIZE ALL DENuded AREAS AND MAINTAIN EROSION CONTROL MEASURES CONTINUOUSLY BETWEEN OCTOBER 15TH AND APRIL 15TH.
- REMOVE SPOILS PROMPTLY AND AVOID STOCKPILING OF FILL MATERIALS WHEN RAIN IS FORECAST. IF RAIN THREATENS, STOCK-PILED SOILS AND OTHER MATERIALS SHALL BE TARPED, AT THE REQUEST OF THE ENGINEER.
- STORE, HANDLE AND DISPOSE OF CONSTRUCTION MATERIALS AND WASTES AS TO PREVENT THEIR ENTRY TO THE STORM DRAIN SYSTEM. CONTRACTOR MUST NOT ALLOW CONCRETE, WASH-WATERS, SLURRIES, PAINT OR OTHER MATERIALS TO ENTER CATCH BASINS OR TO ENTER SITE RUNOFF.
- USE FILTRATION OR OTHER MEASURES TO REMOVE SEDIMENT FROM DEWATERING EFFLUENT.
- NO CLEANING, FUELING OR MAINTAINING VEHICLES ON SITE SHALL BE PERMITTED IN ANY MANNER THAT ALLOWS DELETERIOUS MATERIALS TO ENTER CATCH BASINS OR TO ENTER SITE RUNOFF.
- USE OF PESTICIDES AND/OR FERTILIZERS SHALL BE APPLIED AND CONTROLLED TO PREVENT POLLUTION RUNOFF.
- IN THE EVENT GRADING OPERATIONS ARE SUSPENDED BY WEATHER CONDITIONS AND IF THE STORM DRAIN SYSTEM IS INCOMPLETE, INSTALL ADDITIONAL ROCK FILTERS AND OTHER FACILITIES AS DIRECTED BY THE ENGINEER.
- CONTRACTOR TO RELOCATE CONCRETE WASHDOWN, VEHICLE STORAGE DELIVERY, AND NON-HAZARDOUS WASTE AREAS AS NECESSARY TO FACILITATE THEIR OPERATION AND PROMOTE POLLUTION CONTROL.

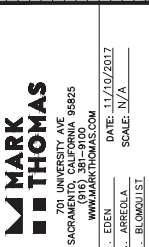
**90% SUBMITTAL - NOT FOR CONSTRUCTION**

	
DESIGNED BY: J. EDEN DRAWN BY: A. JARRELLA CHECKED BY: D. BLOROUSET	
DATE: 11/10/2017 SCALE: 1/4" = 1'-0"	
REGISTERED PROFESSIONAL ENGINEER DANIEL THOMAS #00000000 No. 65875 Exp. 12/31/17 CIVIL STATE OF CALIFORNIA	
IMPROVEMENT PLANS FOR <b>STATE OF GOOD REPAIR                  BUS STOP IMPROVEMENTS</b> <b>GENERAL NOTES</b>	
	
711 GRAND AVE. SUITE 100 SAN RAFAEL, CA 94901 415.452.1000	
GN-1	PROJECT NO. <b>CC-17104</b>
SHEET 2 OF TBD	CALIFORNIA MARIN COUNTY



**CONSTRUCTION NOTES (THIS SHEET ONLY)**

- 1 FURNISH AND INSTALL BUS SHELTER WITH 4' BENCH PER MCTD DRAWING 24446-00. [INSTALL VICTORIAN-STYLE METAL SCREEN BACK PANEL PER TOLAR REQUIREMENTS]
- 2 REMOVE AND DISPOSE EXISTING BENCH. AFTER BENCH REMOVAL, GRIND ANCHOR BOLTS FLUSH WITH EXISTING SIDEWALK.
- 3 RELOCATE TRASH RECEPTACLE TO LOCATION SHOWN ON THE PLAN. REINSTALL RELOCATED TRASH RECEPTACLE WITH NEW ANCHOR BOLTS. GRIND ANCHOR BOLTS FLUSH WITH EXISTING SIDEWALK.
- 4 PRIOR TO WORK IN FRONT OF PROPERTY, NOTIFY CHARLES SCHWAB ONE WEEK IN ADVANCE (PHONE 415-945-6464). ACCESS TO REMAIN OPEN DURING CONSTRUCTION.

**TEMPORARY BUS STOP NOTES**

1. TEMPORARY BUS STOP TO BE LOCATED 55 FEET FROM THE END OF THE NORTHWEST CURB RETURN AT THE CORTE MADERA TOWN CENTER AND TAMALPAIS DRIVE INTERSECTION.
2. CONTRACTOR SHALL COORDINATE WITH MCTD AND GGBHTD FOR INSTALLATION OF TEMPORARY BUS STOP SIGNAGE. CONTRACTOR SHALL MAINTAIN BUS ACCESS AND TEMPORARY SIGNAGE AT ALL TIMES.

**COORDINATION NOTES**

1. CONTRACTOR SHALL COORDINATE WITH TOWN OF CORTE MADERA FOR ENCROACHMENT PERMIT PRIOR TO THE START OF WORK. CONTACT IS NISHA PATEL AT (415) 927-5120. DO NOT START WORK WITHOUT AN APPROVED ENCROACHMENT PERMIT.
2. CONTRACTOR SHALL SUBMIT A TRAFFIC CONTROL PLAN TO MCTD AND THE TOWN NO LESS THAN TEN WORKING DAYS PRIOR TO BEGINNING CONSTRUCTION. DO NOT START WORK WITHOUT AN APPROVED TRAFFIC CONTROL PLAN.
3. CONTRACTOR SHALL PROTECT MONUMENTS IN PLACE AND SHALL NOTIFY THE ENGINEER AND TOWN IF ANY ARE IDENTIFIED WITHIN THE LIMITS OF WORK.

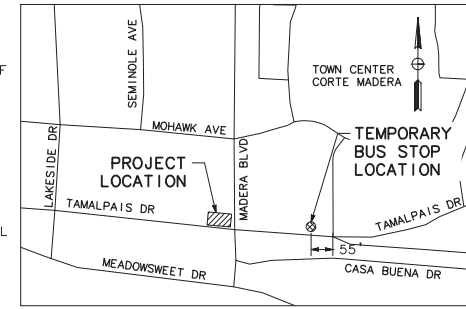

**VICINITY MAP**  
SCALE: NTS

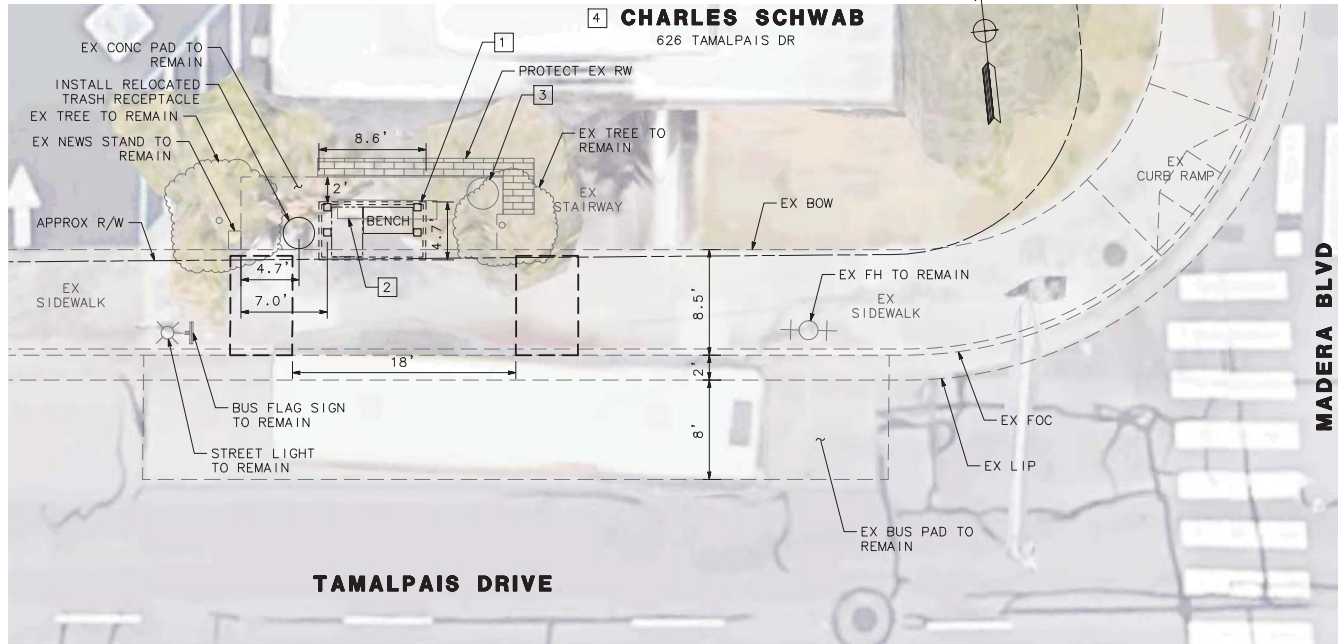

**PLAN**  
SCALE: 1" = 5'

**90% SUBMITTAL - NOT FOR CONSTRUCTION**

NO.	DATE	REVISION DESCRIPTION

**MARK THOMAS**  
REGISTERED PROFESSIONAL ENGINEER  
711 GRAND AVENUE SUITE 100  
SACRAMENTO, CALIFORNIA 95825  
(916) 381-9100  
WWW.MARKTHOMAS.COM

DESIGNED BY: J. EDEN DATE: 11/10/2017  
DRAWN BY: A. JARRELA SCALE: AS NOTED  
CHECKED BY: D. BLODGETT

**ENGINEERS STAMP**

REGISTERED PROFESSIONAL ENGINEER  
DANIEL THOMAS BLODGETT  
No. 65875 Exp. 12/31/17  
STATE OF CALIFORNIA  
DATE SIGNED:

IMPROVEMENT PLANS FOR  
**STATE OF GOOD REPAIR  
BUS STOP IMPROVEMENTS  
LAYOUT PLAN  
TAMALPAIS DR AT  
MADERA BLVD  
(MT ID 40280)**

MARIN COUNTY CALIFORNIA

**marintransit**

711 GRAND AVE. SUITE 100  
SACRAMENTO, CA 95825  
916.381.9100

<b>L-1</b>
PROJECT NO. <b>CC-17104</b>
SHEET 3 OF TBD



**CONSTRUCTION NOTES** (THIS SHEET ONLY)

- 1. CONSTRUCT TYPE "A" SIDEWALK PER MARIN CO. UCS DWG. NO. 105. (WIDTH PER PLAN). REMOVE AND DISPOSE OF EXISTING CONCRETE CURB, GUTTER AND SIDEWALK PER MARIN CO. UCS DWG. NO. 100.
- 2. REMOVE EXISTING VEGETATED PLANTER STRIP.
- 3. SAWCUT, REMOVE AND DISPOSE OF EXISTING ASPHALT PAVEMENT SECTION PER MARIN CO. UCS DWG. NO. 100. CONSTRUCT 12" MINIMUM FULL DEPTH HMA PAVEMENT SECTION.
- 4. RELOCATE BUS FLAG SIGN TO NEW POST PER MARIN CO. UCS DWG. NO. 310. REMOVE AND DISPOSE OF EXISTING SIGN POST.
- 5. FURNISH AND INSTALL BUS SHELTER WITH 4' BENCH PER MCTD DRAWING 24446-00.
- 6. REMOVE AND DISPOSE OF EXISTING BENCH.
- 7. RELOCATE TRASH RECEPTACLE TO THE LOCATION SHOWN ON THE PLAN.
- 8. ADJUST SANITARY SEWER CLEANOUT TO GRADE.
- 9. PRESERVE AND PROTECT TRAFFIC SIGNAL BOX.
- 10. EXIST TELECOM BOX TO REMAIN.
- 11. INSTALL DETAIL 27B THERMOPLASTIC TRAFFIC STRIP PER CALTRANS STD PLAN A20B.

**TEMPORARY BUS STOP NOTES**

- 1. TEMPORARY BUS STOP TO BE LOCATED NEAR THE NEWSTAND AT THE INTERSECTION OF RED HILL AVE AND 45 FEET WEST FROM THE STOP SIGN AT FORBES AVE.
- 2. CONTRACTOR SHALL COORDINATE WITH MCTD AND GGBHTD FOR INSTALLATION OF TEMPORARY BUS STOP SIGNAGE. CONTRACTOR SHALL MAINTAIN BUS ACCESS AND TEMPORARY SIGNAGE AT ALL TIMES.

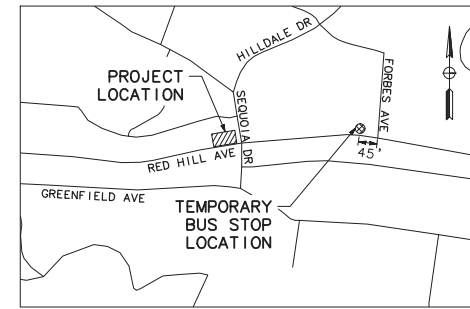

**VICINITY MAP**

SCALE: NTS

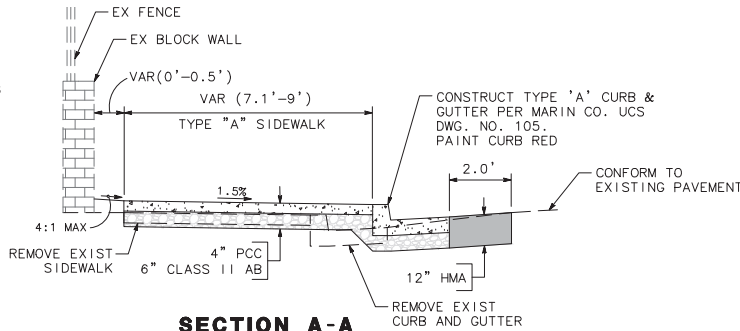

**SECTION A-A**

SCALE: NTS

**CURVE DATA**

No.	R	Δ	T	L
1	10.00'	27°29'30"	2.45'	4.80'
2	8.00'	27°15'57"	1.94'	3.81'

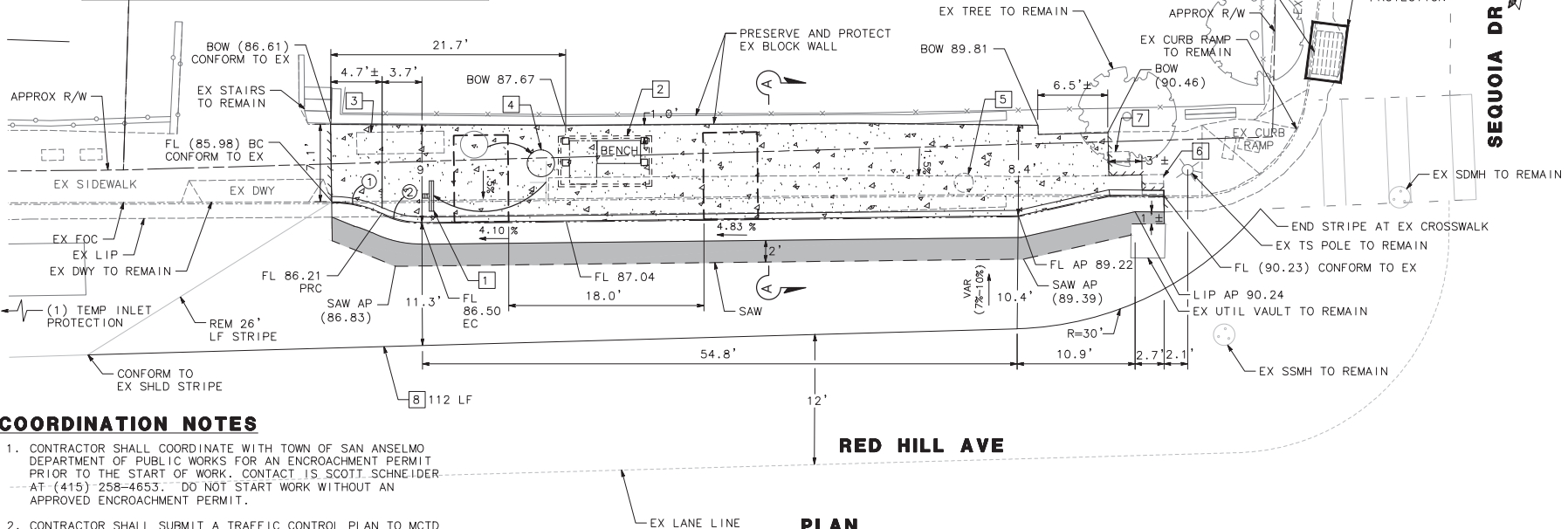

**PLAN**

SCALE: 1" = 5'

**COORDINATION NOTES**

- 1. CONTRACTOR SHALL COORDINATE WITH TOWN OF SAN ANSELMO DEPARTMENT OF PUBLIC WORKS FOR AN ENCROACHMENT PERMIT PRIOR TO THE START OF WORK. CONTACT IS SCOTT SCHNEIDER AT (415) 258-4653. DO NOT START WORK WITHOUT AN APPROVED ENCROACHMENT PERMIT.
- 2. CONTRACTOR SHALL SUBMIT A TRAFFIC CONTROL PLAN TO MCTD AND THE TOWN NO LESS THAN TEN WORKING DAYS PRIOR TO BEGINNING CONSTRUCTION. DO NOT START WORK WITHOUT AN APPROVED TRAFFIC CONTROL PLAN.
- 3. CONTRACTOR SHALL PROTECT MONUMENTS IN PLACE AND SHALL NOTIFY THE ENGINEER AND TOWN IF ANY ARE IDENTIFIED WITHIN THE LIMITS OF WORK.

**90% SUBMITTAL - NOT FOR CONSTRUCTION**

**MARK THOMAS**  
 CIVIL ENGINEER  
 711 GRAND AVE SUITE 100  
 SACRAMENTO, CALIFORNIA 95825  
 (916) 381-9100  
 WWW.MARKTHOMAS.COM

DESIGNED BY: J. EDEN  
 DRAWN BY: A. JARCELA  
 CHECKED BY: D. BLOROUSSET

DATE: 11/10/2017  
 SCALE: AS SHOWN

**STATE OF GOOD REPAIR BUS STOP IMPROVEMENTS LAYOUT PLAN**  
 RED HILL AVE AT SEQUOIA DR  
 (MT ID 40490)

**marintransit**  
 711 GRAND AVE SUITE 100  
 SAN ANSELMO, CA 94903  
 (415) 435-7400

**L-3**  
 PROJECT NO. CC-17104  
 SHEET 5 OF TBD

CAD USER: jeden  
 PLOT DATE: Nov 09 2017 11:39:42am  
 FILE NAME: 05-40490 - Red Hill Ave and Sequoia Dr  
 PATH: \\valuediv\Projects\Marin\_Transit-CC-17104-On-Call\GES\CADD\Sheets

CAD USER: jeden

FILE NAME: 06-40449 - Medway Rd and E Francisco Blvd.plt DATE: Nov 09 2017 11:41:04am

PATH: \\valfield\Projects\Marin\_Transit-CC-17104-On-Call\GES\CADD\Sheets\

**CONSTRUCTION NOTES (THIS SHEET ONLY)**

- 1 FURNISH AND INSTALL BUS SHELTER AND BENCH PER MCTD DRAWING 24446-00.
- 2 REMOVE AND SALVAGE EXISTING BENCH. AFTER BENCH REMOVAL, GRIND ANCHOR BOLTS FLUSH WITH EXISTING SIDEWALK.
- 3 RELOCATE BUS FLAG SIGN TO NEW POST PER MARIN COUNTY UCS DWG. NO. 310. REMOVE AND DISPOSE OF EXISTING SIGN POST.

**TEMPORARY BUS STOP NOTES**

1. TEMPORARY BUS STOP TO BE LOCATED 35 FEET IN THE NORTHEAST DIRECTION FROM THE SOUTHEAST CURB RETURN AT THE INTERSECTION OF MEDWAY ROAD AND EAST FRANCISCO BOULEVARD.
2. CONTRACTOR SHALL COORDINATE WITH MCTD AND GGBHTD FOR INSTALLATION OF TEMPORARY BUS STOP SIGNAGE. CONTRACTOR SHALL MAINTAIN BUS ACCESS AND TEMPORARY SIGNAGE AT ALL TIMES.

**COORDINATION NOTES**

1. CONTRACTOR SHALL COORDINATE WITH CITY OF SAN RAFAEL DEPARTMENT OF PUBLIC WORKS FOR AN ENCROACHMENT PERMIT PRIOR TO THE START OF WORK. CONTACT IS HUNTER YOUNG AT (415) 485-3408. DO NOT START WORK WITHOUT AN APPROVED ENCROACHMENT PERMIT.
2. CONTRACTOR SHALL SUBMIT A TRAFFIC CONTROL PLAN TO MCTD AND THE CITY NO LESS THAN TEN WORKING DAYS PRIOR TO BEGINNING CONSTRUCTION. DO NOT START WORK WITHOUT AN APPROVED TRAFFIC CONTROL PLAN.
3. CONTRACTOR SHALL PROTECT MONUMENTS IN PLACE AND SHALL NOTIFY THE ENGINEER AND CITY IF ANY ARE IDENTIFIED WITHIN THE LIMITS OF WORK.

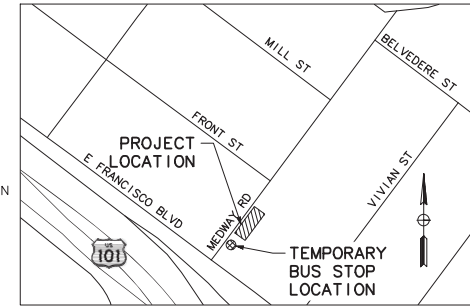

**VICINITY MAP**

SCALE: NTS

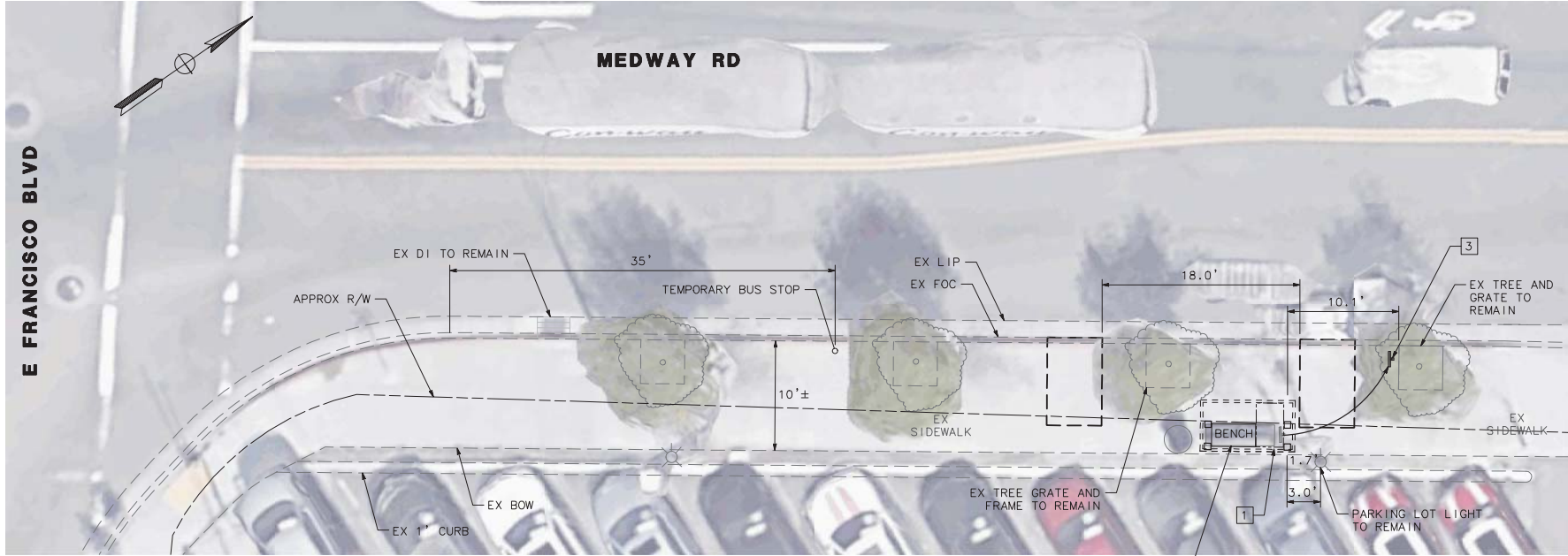

**PLAN**

SCALE: 1" = 5'

**90% SUBMITTAL - NOT FOR CONSTRUCTION**

NO.	DATE	REVISION DESCRIPTION

**MARK THOMAS**  
 CIVIL ENGINEER  
 711 GRAND AVE. SUITE 100  
 SAN RAFAEL, CALIFORNIA 94925  
 SACRAMENTO, CALIFORNIA 95825  
 (916) 381-9100  
 WWW.MARKTHOMAS.COM

DESIGNED BY: J. EDEN DATE: 11/10/2017  
 DRAWN BY: A. JAREDELA SCALE: AS NOTED  
 CHECKED BY: D. BLODGETT

**ENGINEER'S STAMP**

RESIGNED  
 PROFESSIONAL ENGINEER  
 DANIEL THOMAS BLODGETT  
 No. 65875  
 Exp. 12/31/17  
 STATE OF CALIFORNIA  
 CIVIL

DATE SIGNED:

IMPROVEMENT PLANS FOR  
**STATE OF GOOD REPAIR  
 BUS STOP IMPROVEMENTS  
 LAYOUT PLAN  
 MEDWAY RD AT  
 E FRANCISCO BLVD**  
 MARIN COUNTY CALIFORNIA  
 (MT ID 40449)

**marintransit**

711 GRAND AVE. SUITE 100  
 SAN RAFAEL, CA 94925  
 (415) 485-3408

<b>L-4</b>
PROJECT NO. <b>CC-17104</b>
SHEET 6 OF TBD



**CONSTRUCTION NOTES**

- CONSTRUCT TYPE "A" SIDEWALK PER MARIN CO. UCS DWG NO. 105. (WIDTH PER PLAN). CONSTRUCT DRIVEWAY PER MARIN COUNTY UCS DWG NO. 115, 120. REMOVE AND DISPOSE OF EXISTING CONCRETE CURB, GUTTER AND SIDEWALK PER MARIN CO. UCS DWG. NO. 100.
- SAWCUT, REMOVE AND DISPOSE OF EXISTING ASPHALT PAVEMENT SECTION PER COUNTY OF MARIN CO. UCS DWG. NO. 100. CONSTRUCT 12" MINIMUM FULL DEPTH HMA PAVEMENT SECTION.
- CONSTRUCT 2" HMA CONFORM OVER 4" CLASS II AB FOR EXISTING PATH
- CONSTRUCT 6" HMA OVER 6" CLASS II AB FOR EXISTING DRIVEWAY.
- 1 RELOCATE BUS FLAG SIGN TO NEW POST PER MARIN CO. UCS DWG. NO. 310. REMOVE AND DISPOSE EXISTING POST.
- 2 FURNISH AND INSTALL BUS SHELTER WITH 4' BENCH PER MCTD DRAWING 24446-00.
- 3 REMOVE AND DISPOSE EXISTING BENCH.
- 4 INSTALL CURB AND GUTTER TYPE A2-6 FROM CALTRANS STD PLAN A87A. PAINT CURB RED.
- 5 REMOVE AND DISPOSE WOOD RETAINING BOARD.
- 6 PROTECT EXISTING FENCE TO REMAIN.

**TEMPORARY BUS STOP NOTES**

1. TEMPORARY BUS STOP TO BE LOCATED APPROXIMATELY 65 FEET WEST OF THE 76 GAS STATION DRIVEWAY NEAR THE TIBURON BLVD AND GREENWOOD COVE DR INTERSECTION.
2. CONTRACTOR SHALL COORDINATE WITH MCTD AND GGBHTD FOR INSTALLATION OF TEMPORARY BUS STOP SIGNAGE. CONTRACTOR SHALL MAINTAIN BUS ACCESS AND TEMPORARY SIGNAGE AT ALL TIMES.

CURVE DATA

No.	R	Δ	T	L
1	822.00'	7°32'53"	54.22'	108.29'

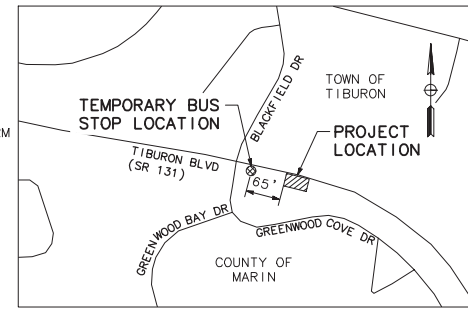
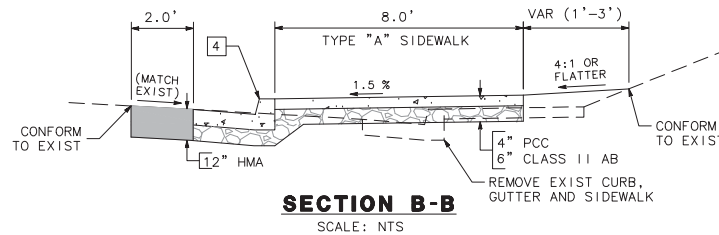
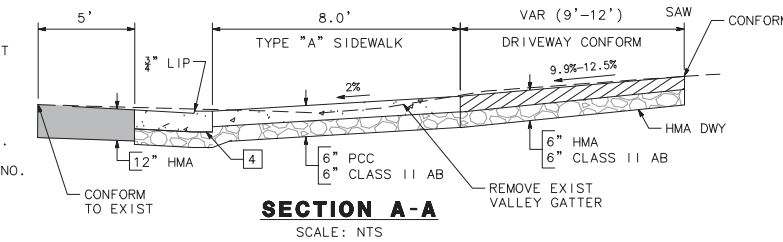

**COORDINATION NOTES**

1. CONTRACTOR SHALL COORDINATE WITH CALTRANS FOR ENCROACHMENT PERMIT. CONTACT IS TO BE DETERMINED. DO NOT START WORK WITHOUT AN ENCROACHMENT PERMIT.
2. CONTRACTOR SHALL SUBMIT A TRAFFIC CONTROL PLAN TO MCTD AND COUNTY OF MARIN TEN WORKING DAYS PRIOR TO BEGINNING CONSTRUCTION. DO NOT START WORK WITHOUT AN APPROVED TRAFFIC CONTROL PLAN.
3. CONTRACTOR SHALL PROTECT MONUMENTS IN PLACE AND SHALL NOTIFY THE ENGINEER IF ANY ARE IDENTIFIED WITHIN THE LIMITS OF WORK.

**TIBURON BLVD (SR 131)**

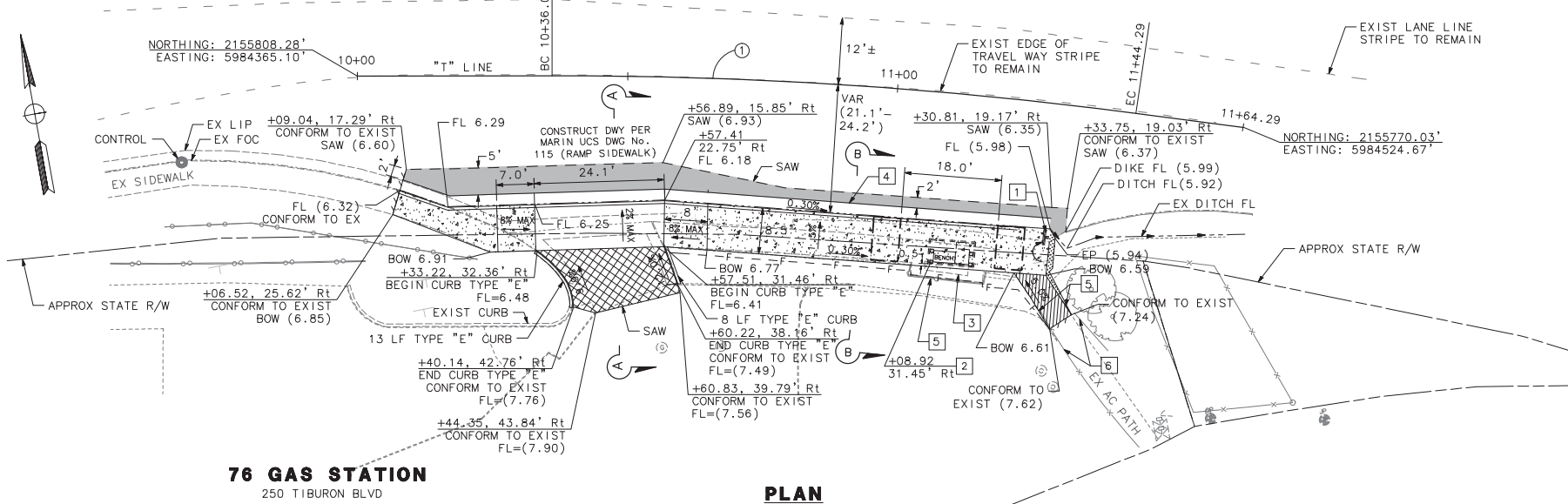

**76 GAS STATION**  
250 TIBURON BLVD

**90% SUBMITTAL - NOT FOR CONSTRUCTION**

FILE NAME: 07-40223 - Tiburon Blvd and Greenwood Cove (R) DATE: Nov. 09, 2017 - 01:49:21pm

CAD USER: jeden

DATE: 11/16/2017  
SCALE: AS NOTED  
DESIGNED BY: J. EDEN  
DRAWN BY: A. JAREOLA  
CHECKED BY: D. BLODGETT

**MARK THOMAS ENGINEERS**  
711 GRAND AVE. SUITE 100  
SAN RAFAEL, CA 94901  
TEL: (415) 452-1100  
WWW.MARKTHOMAS.COM

**IMPROVEMENT PLANS FOR  
STATE OF GOOD REPAIR  
BUS STOP IMPROVEMENTS  
LAYOUT PLAN  
TIBURON BLVD AT  
GREENWOOD COVE DR  
(MT ID 40223)**

PROJECT NO.  
**CC-17104**

SHEET 7 OF TBD



**CONSTRUCTION NOTES (THIS SHEET ONLY)**

- 1. CONSTRUCT TYPE "A" SIDEWALK PER MARIN CO. UCS DWG NO. 105. (WIDTH PER PLAN). REMOVE AND DISPOSE OF EXISTING CONCRETE CURB, GUTTER AND SIDEWALK PER COUNTY OF MARIN UCS DWG NO. 100.
- 2. SAWCUT, REMOVE AND DISPOSE OF EXISTING ASPHALT PAVEMENT SECTION PER COUNTY OF MARIN UCS DWG NO. 100. CONSTRUCT TO 12" MINIMUM FULL DEPTH HMA PAVEMENT SECTION.
- 3. RELOCATE BUS FLAG SIGN TO NEW POST PER MARIN CO. UCS DWG NO. 310. REMOVE AND DISPOSE OF EXISTING SIGN POST.
- 4. RELOCATE STOP SIGN TO NEW POST PER MARIN CO. UCS DWG NO. 310. REMOVE AND DISPOSE OF EXISTING SIGN POST.
- 5. ADJUST WATER METER BOX TO GRADE.
- 6. NOTIFY PROPERTY OWNER 7 DAYS IN ADVANCE OF CONSTRUCTION.

**TEMPORARY BUS STOP NOTES**

- 1. TEMPORARY BUS STOP TO BE LOCATED AT THE START OF THE CURB RETURN AT CONSTANCE DR AND LOS RANCHITOS RD INTERSECTION.
- 2. CONTRACTOR SHALL COORDINATE WITH MCTD AND GGBHTD FOR INSTALLATION OF TEMPORARY BUS STOP SIGNAGE. CONTRACTOR SHALL MAINTAIN BUS ACCESS AND TEMPORARY SIGNAGE AT ALL TIMES.

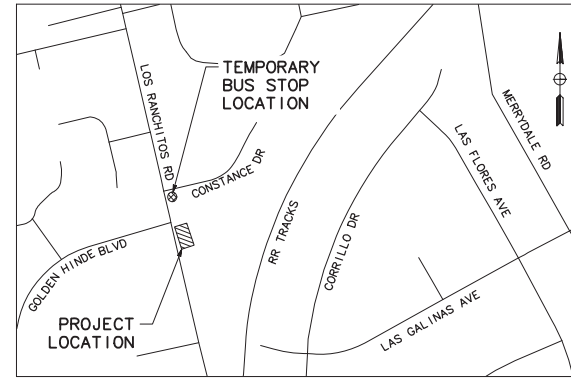

**VICINITY MAP**

SCALE: NTS

**COORDINATION NOTES**

- 1. CONTRACTOR SHALL COORDINATE WITH CITY OF SAN RAFAEL DEPARTMENT OF PUBLIC WORKS FOR AN ENCROACHMENT PERMIT PRIOR TO THE START OF WORK. CONTACT IS HUNTER YOUNG AT (415) 485-3408. DO NOT START WORK WITHOUT AN APPROVED ENCROACHMENT PERMIT.
- 2. CONTRACTOR SHALL SUBMIT A TRAFFIC CONTROL PLAN TO MCTD AND THE CITY NO LESS THAN TEN WORKING DAYS PRIOR TO BEGINNING CONSTRUCTION. DO NOT START WORK WITHOUT AN APPROVED TRAFFIC CONTROL PLAN.
- 3. CONTRACTOR SHALL PROTECT MONUMENTS IN PLACE AND SHALL NOTIFY THE ENGINEER AND CITY IF ANY ARE IDENTIFIED WITHIN THE LIMITS OF WORK.

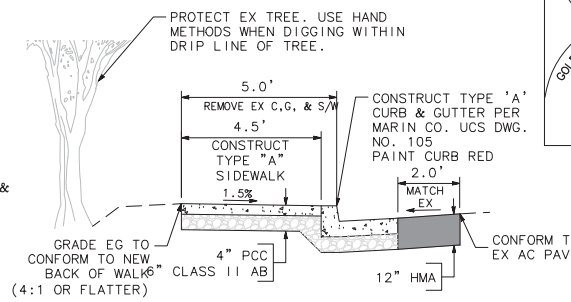

**SECTION B-B**

SCALE: NTS

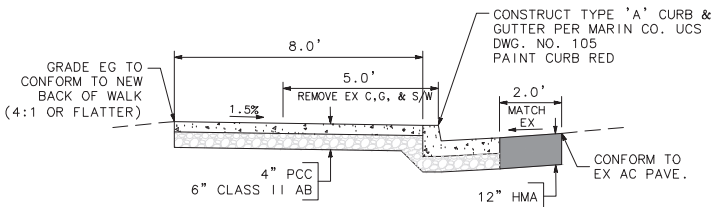

**SECTION A-A**

SCALE: NTS

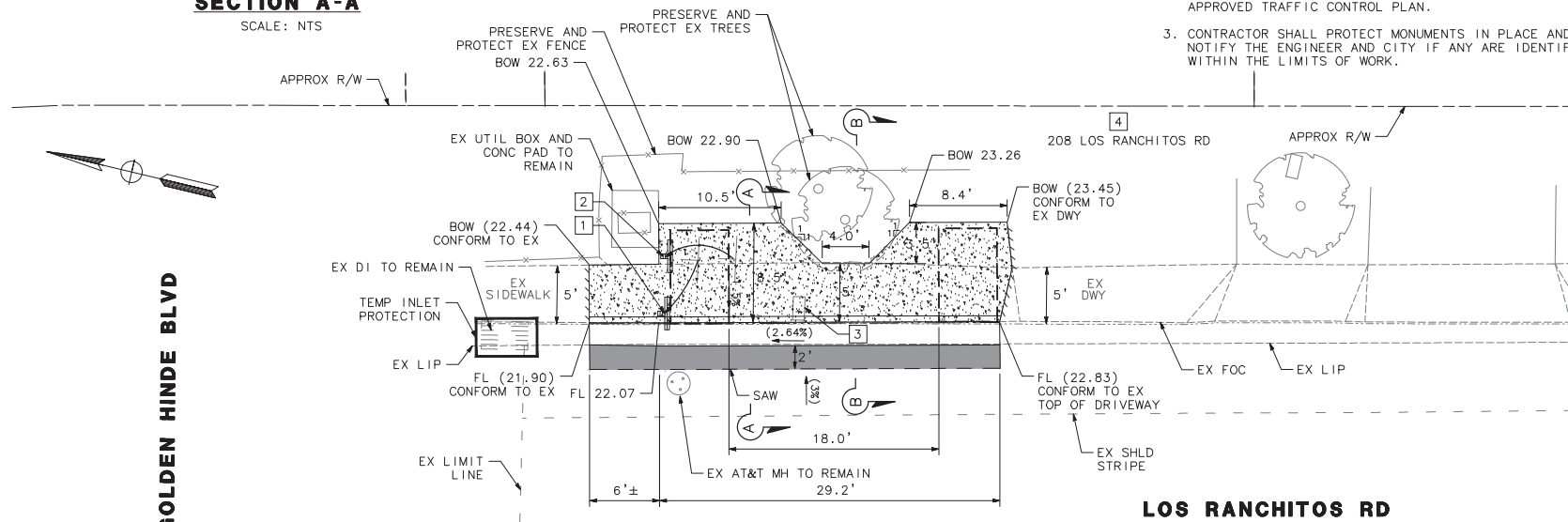

**PLAN**

SCALE: 1" = 5'

**90% SUBMITTAL - NOT FOR CONSTRUCTION**

NO.	DATE	REVISION DESCRIPTION

**MARK THOMAS**  
 CIVIL ENGINEER  
 711 GRAND AVENUE SUITE 100  
 SAN RAFAEL, CA 94901  
 (916) 381-9100  
 WWW.MARKTHOMAS.COM  
 DATE: 11/10/2017  
 DESIGNED BY: J. EDEEN  
 DRAWN BY: A. JARECELA  
 CHECKED BY: D. BLODGETT  
 SCALE: AS NOTED

**ENGINEERS STAMP**  
 PROFESSIONAL ENGINEER  
 DANIEL THOMAS BLODGETT  
 No. 65875  
 Exp. 12/31/21  
 STATE OF CALIFORNIA  
 CIVIL  
 DATE SIGNED:  



IMPROVEMENT PLANS FOR  
**STATE OF GOOD REPAIR  
 BUS STOP IMPROVEMENTS  
 LAYOUT PLAN  
 LOS RANCHITOS RD  
 AT GOLDEN HINDE BLVD  
 (MT ID 40572)**  
 CALIFORNIA  
 MARRIN COUNTY

**marintransit**  
 711 GRAND AVENUE SUITE 100  
 SAN RAFAEL, CA 94901  
 (415) 485-3408  
 WWW.MARINTRANSIT.COM

**L-7**  
 PROJECT NO.  
**CC-17104**  
 SHEET 9 OF TBD

CAD USER: j eden  
 FILE NAME: 09-40572 - Los Ranchitos Rd and Golden Hinde Blvd (ATE: Nov 09 2017-11:43:26am)  
 PATH: \\alfred\IT\Projects\Marin\_Transit-CC-17104-0n-Call\_GES\CADD\Sheets\

**CONSTRUCTION NOTES** (THIS SHEET ONLY)

-  CONSTRUCT TYPE "B" SIDEWALK PER MARIN CO. UCS DWG NO. 105. REMOVE AND DISPOSE OF EXISTING CONCRETE SIDEWALK, IN CONFLICT WITH THE NEW SIDEWALK PER MARIN CO. UCS DWG NO. 100.
-  REMOVE EXISTING VEGETATED PLANTER STRIP.
-  RELOCATE BUS FLAG SIGN TO NEW POST PER MARIN COUNTY UCS DWG NO. 310. REMOVE AND DISPOSE OF EXISTING SIGN POST.

**TEMPORARY BUS STOP NOTES**

1. TEMPORARY BUS STOP TO BE LOCATED APPROXIMATELY 270 FEET FROM THE BUS STOP FLAG SIGN AT THE PROJECT LOCATION. ADD 5' x 2' AREA OF HMA.
2. CONTRACTOR SHALL COORDINATE WITH MCTD AND GGBHTD FOR INSTALLATION OF TEMPORARY BUS STOP SIGNAGE. CONTRACTOR SHALL MAINTAIN BUS ACCESS AND TEMPORARY SIGNAGE AT ALL TIMES.

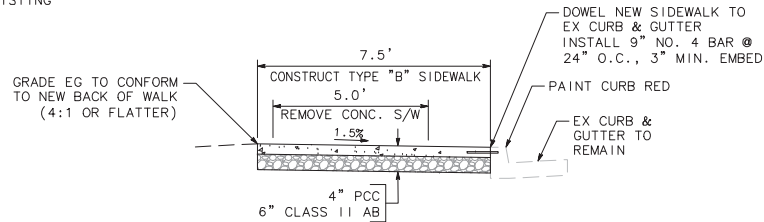

**SECTION A-A**

SCALE: NTS

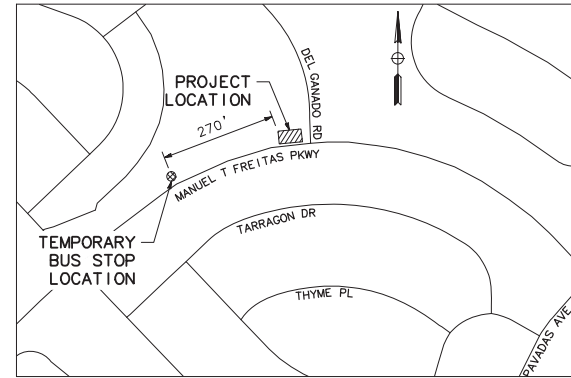

**VICINITY MAP**

SCALE: NTS

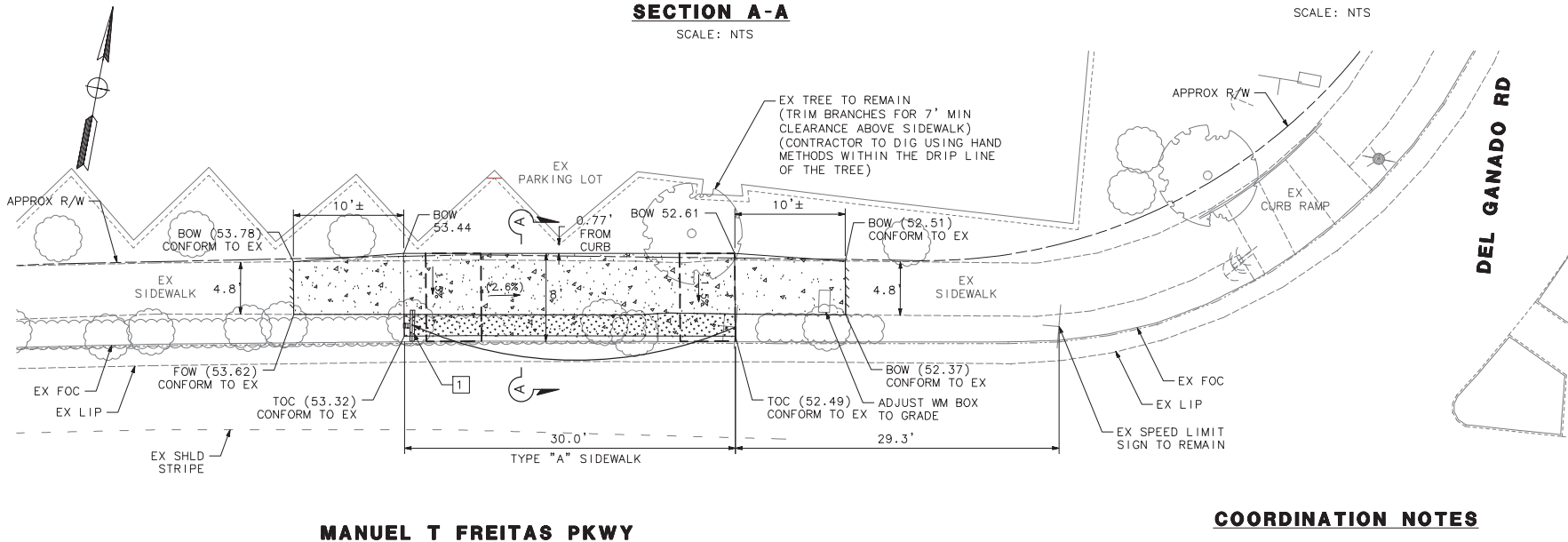

**MANUEL T FREITAS PKWY**

**PLAN**

SCALE: 1" = 5'

**COORDINATION NOTES**

1. CONTRACTOR SHALL COORDINATE WITH CITY OF SAN RAFAEL DEPARTMENT OF PUBLIC WORKS FOR AN ENCROACHMENT PERMIT PRIOR TO THE START OF WORK. CONTACT IS HUNTER YOUNG AT (415) 485-3408. DO NOT START WORK WITHOUT AN APPROVED ENCROACHMENT PERMIT.
2. CONTRACTOR SHALL SUBMIT A TRAFFIC CONTROL PLAN TO MCTD AND THE CITY NO LESS THAN TEN WORKING DAYS PRIOR TO BEGINNING CONSTRUCTION. DO NOT START WORK WITHOUT AN APPROVED TRAFFIC CONTROL PLAN.
3. CONTRACTOR SHALL PROTECT MONUMENTS IN PLACE AND SHALL NOTIFY THE ENGINEER AND CITY IF ANY ARE IDENTIFIED WITHIN THE LIMITS OF WORK.

**90% SUBMITTAL - NOT FOR CONSTRUCTION**

NO.	DATE	REVISION DESCRIPTION

**MARK THOMAS**  
 CIVIL ENGINEER  
 71 GRAND AVE. SUITE 100  
 SAN RAFAEL, CA 94903  
 (916) 381-9100  
 WWW.MARKTHOMAS.COM

DESIGNED BY: J. EDEN DATE: 11/10/2017  
 DRAWN BY: A. JAREOLA SCALE: AS NOTED  
 CHECKED BY: D. BLODGETT

**ENGINEER'S STAMP**

RESERVED PROFESSIONAL ENGINEER VERIFIED  
 DANIEL THOMAS #00000218  
 No. 65875 Exp. 12/31/17  
 STATE OF CALIF. CIVIL

IMPROVEMENT PLANS FOR  
**STATE OF GOOD REPAIR  
 BUS STOP IMPROVEMENTS  
 LAYOUT PLAN  
 MANUEL T FREITAS PKWY  
 AT DEL GANADO RD  
 (MT ID 40549)**

MARIN COUNTY CALIFORNIA



71 GRAND AVE. SUITE 100  
 SAN RAFAEL, CA 94903  
 (415) 485-3408

<b>L-8</b>	PROJECT NO. <b>CC-17104</b>	SHEET 10 OF TBD
------------	--------------------------------	-----------------





**CONSTRUCTION NOTES** (THIS SHEET ONLY)

- 1. CONSTRUCT TYPE "B" SIDEWALK PER MARIN CO. UCS DWG NO. 105. (WIDTH PER PLAN). REMOVE AND DISPOSE OF EXISTING CONCRETE SIDEWALK PER MARIN CO. UCS DWG. NO. 100.
- 2. RELOCATE BUS FLAG SIGN TO NEW POST PER MARIN CO. UCS DWG. NO. 310. REMOVE AND DISPOSE EXISTING POST.
- 3. FURNISH AND INSTALL BUS SHELTER WITH 4' BENCH PER MCTD DRAWING 24446-00.
- 4. REMOVE AND RELOCATE TRASH RECEPTACLE TO LOCATION SHOWN ON THE PLAN. REINSTALL RELOCATED TRASH RECEPTACLE WITH NEW ANCHOR BOLTS.

**COORDINATION NOTES**

- 1. CONTRACTOR SHALL COORDINATE WITH CITY OF LARKSPUR DEPARTMENT OF PUBLIC WORKS FOR AN ENCROACHMENT PERMIT PRIOR TO THE START OF WORK. CONTACT IS JULIAN SKINNER AT (415) 927-5017. DO NOT START WORK WITHOUT AN APPROVED ENCROACHMENT PERMIT.
- 2. CONTRACTOR SHALL SUBMIT A TRAFFIC CONTROL PLAN TO MCTD AND THE CITY NO LESS THAN TEN WORKING DAYS PRIOR TO BEGINNING CONSTRUCTION. DO NOT START WORK WITHOUT AN APPROVED TRAFFIC CONTROL PLAN.
- 3. CONTRACTOR SHALL PROTECT MONUMENTS IN PLACE AND SHALL NOTIFY THE ENGINEER AND CITY IF ANY ARE IDENTIFIED WITHIN THE LIMITS OF WORK.
- 4. CONTRACTOR SHALL NOTIFY PROPERTY OWNER 7 DAYS IN ADVANCE OF START OF CONSTRUCTION.

**TEMPORARY BUS STOP NOTES**

- 1. TEMPORARY BUS STOP TO BE LOCATED APPROXIMATELY 195 FEET NORTHWEST OF THE CONCRETE BUS PAD AT THE PROJECT LOCATION.
- 2. CONTRACTOR SHALL COORDINATE WITH MCTD AND GGBHTD FOR INSTALLATION OF TEMPORARY BUS STOP SIGNAGE. CONTRACTOR SHALL MAINTAIN BUS ACCESS AND TEMPORARY SIGNAGE AT ALL TIMES.

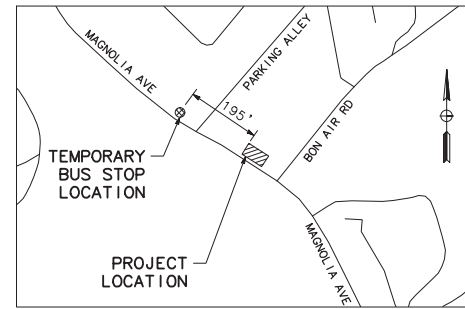

**VICINITY MAP**  
SCALE: NTS

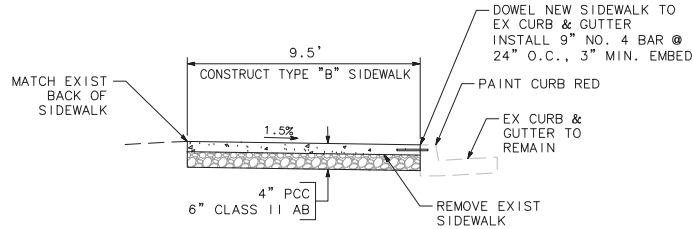

**SECTION A-A**  
SCALE: NTS

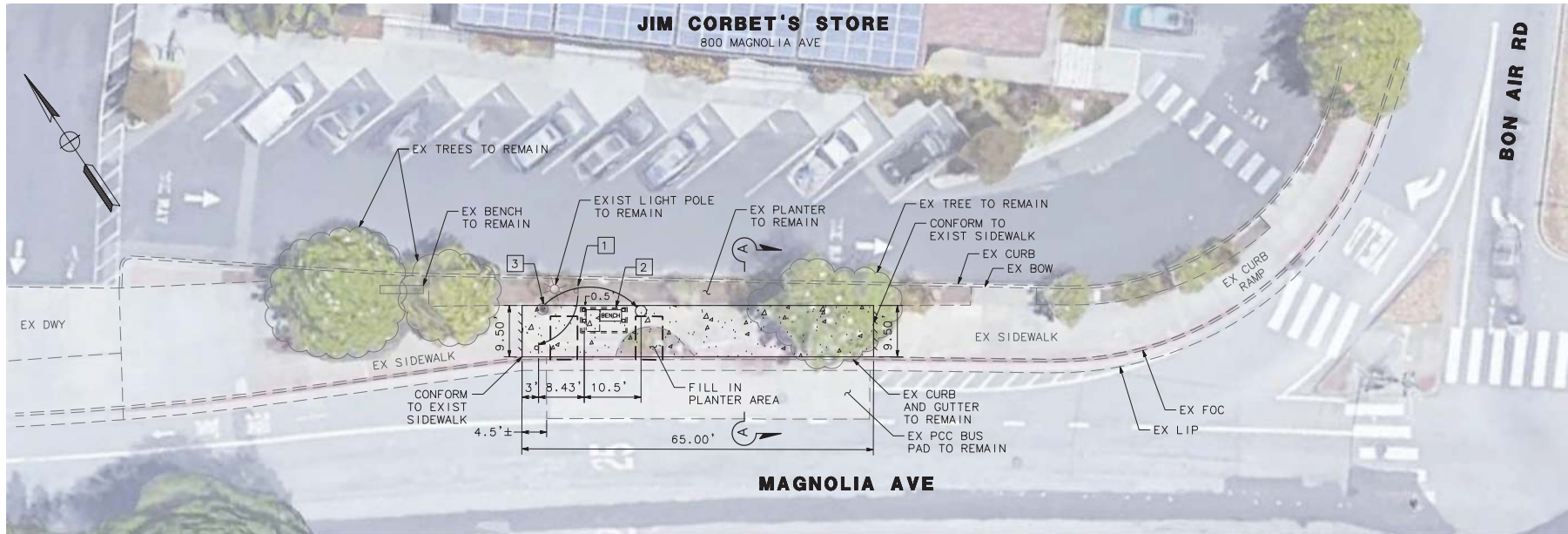

**PLAN**  
SCALE: 1" = 10'

**90% SUBMITTAL - NOT FOR CONSTRUCTION**

<p><b>MARK THOMAS</b> 701 UNIVERSITY AVE SACRAMENTO, CALIFORNIA 95825 (916) 381-9100 WWW.MARKTHOMAS.COM</p>	<p>DESIGNED BY: J. EDEY DRAWN BY: A. ARREGUILA CHECKED BY: D. BELORUSSEL</p>	<p>DATE: 11/10/2017 SCALE: AS NOTED</p>	<p>NO. DATE REVISION DESCRIPTION</p>
<p><b>ENGINEERS STAMP</b></p> <p>DATE SIGNED: _____</p>			
<p>IMPROVEMENT PLANS FOR <b>STATE OF GOOD REPAIR BUS STOP IMPROVEMENTS LAYOUT PLAN MAGNOLIA AVE AT BON AIR RD (MT ID 40302)</b></p>			
<p> 711 GRAND AVE. SUITE 100 SAN RAFAEL, CA 94901 415.483.6600 TDD: 415.483.6607</p>			
<p><b>L-10</b></p>	<p>PROJECT NO. <b>CC-17104</b></p>	<p>MARIN COUNTY CALIFORNIA</p>	
<p>SHEET 12 OF TBD</p>			

CAD USER: jefden  
 PLOT DATE: Nov 09, 2017 09:12:00am  
 FILE NAME: 12-40302 Magnolia Ave at Bon Air  
 PATH: \\alfred\projects\Marin\_Transit\CC-17104-0n-Call\_GES\CADD\Sheets\

